

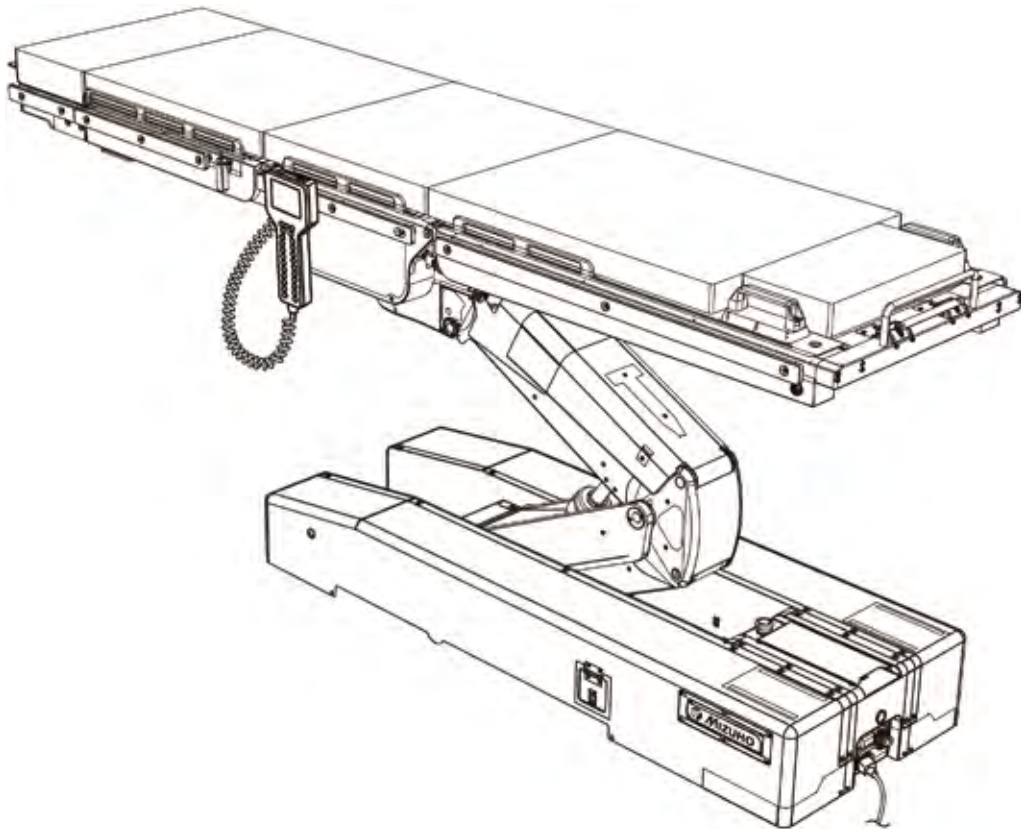

Operating Table MST-7300BX-MR-T Intraoperative Diagnosis Operating Table System Operator's Manual



This operating table is designed to support a patient during surgical procedures. Using it for other purposes may result in damage or injury.

The operator and the person in charge of the maintenance of this operating table must read this operator's manual thoroughly and understand the contents before operating, inspecting, adjusting and maintaining it.

Keep this manual for reference in a place where is readily accessible.

Table of contents

1.	Introduction	1
1.1	This manual	1
1.2	Intended use and this product	1
1.3	Operation of this product	2
1.4	Accessories	2
2.	Safety precaution	4
2.1	Read thoroughly before using	4
2.2	Labeling	9
3.	Component identification	13
3.1	Main unit	13
3.2	Touch panel	14
3.3	Control unit	19
3.4	Foot switch (option)	20
4.	Installation	21
4.1	Installation	21
4.2	Connecting/Disconnecting the control unit	22
4.3	Turning on/off the power	25
4.4	Charging the battery	29
5.	Settings	30
5.1	Changing the temporary stop at the center position	30
5.2	Changing the movement of the lateral tilt	31
5.3	Activating buzzer at limit of travel.....	33
5.4	Switching speed	35

6.	Operation	36
6.1	Display the monitor	36
6.2	Operating the emergency stop switch	37
6.3	Fixing and unfixing the operating table	38
6.4	Tilting the tabletop laterally	39
6.5	Trendelenburg	40
6.6	Tilting the back plate	42
6.7	Tilting the leg plate	44
6.8	Changing the tabletop height	45
6.9	Sliding the tabletop	47
6.10	Operating memory	49
6.11	Checking the current position of the tabletop.....	52
6.12	Returning to level	53
6.13	Connecting with the trolley	54
6.14	Sliding the transfer board	56
6.15	Attaching/detaching head plate	59
6.16	A-line pole	61
7.	Maintenance and inspection	62
7.1	Inspection before and after use	62
7.2	Periodic replacement parts	65
7.3	Version information of the software	65
8.	Specification	66
8.1	Specification table	66
8.2	External view	68
9.	Troubleshooting	69
10.	Before contacting for repairs	76
App.-1	Electromagnetic compatibility	80
App.-2	Glossary	84

1. Introduction

1.1 This manual

This manual contains information for safely and effectively using this product (MST-7300BX-MRI•Mg-T). Before operating this product, read this manual thoroughly to understand how to operate, inspect, adjust and maintain the product.

Failure to follow these instructions could lead to serious injury.

The safety information is categorized as per the following so that the contents of warnings and cautions, and the details of warnings and cautions which are labeled on the product may be comprehended.



If this indication is ignored and the product is incorrectly used, serious injury or death may result.



If this indication is ignored and the product is incorrectly used, serious injury and/or damage to property may result.

NOTE

This notice notes additional information on the product's functions.

The warning and caution notices on this manual relating to operating, inspecting and maintaining, apply to the intended use (surgical operations) of this product.

If the product is used for purposes other than surgery, the user is responsible in regard to safety for performing operations, inspections and repairs which are not contained in this manual.

1.2 Intended use and this product

■ Operating table

This product is an operating table on which a patient is placed for surgical operations.

The product is intended to support a patient during surgical operations.

In conforming with the objectives of surgery, the product is equipped with features for adjusting its height, and for freely changing and setting the patient's body position.

The product uses both medical grade outlets and batteries as power sources.

In the operating room, have physicians, nurses and medical device technicians who are acquainted with the usage of this product use it.

■ Touch panel

This product is provided with a touch panel.

The touch panel displays a status of the operating table and its error status.

For the details of the touch panel, refer to Page 14.

1.3 Operation of this product

The description of the operations written in this manual focuses mainly on those to be done by the control unit. For some operations operable only by the touch panel, however, those by the touch panel are described.

1.4 Accessories

■ Standard components and accessories

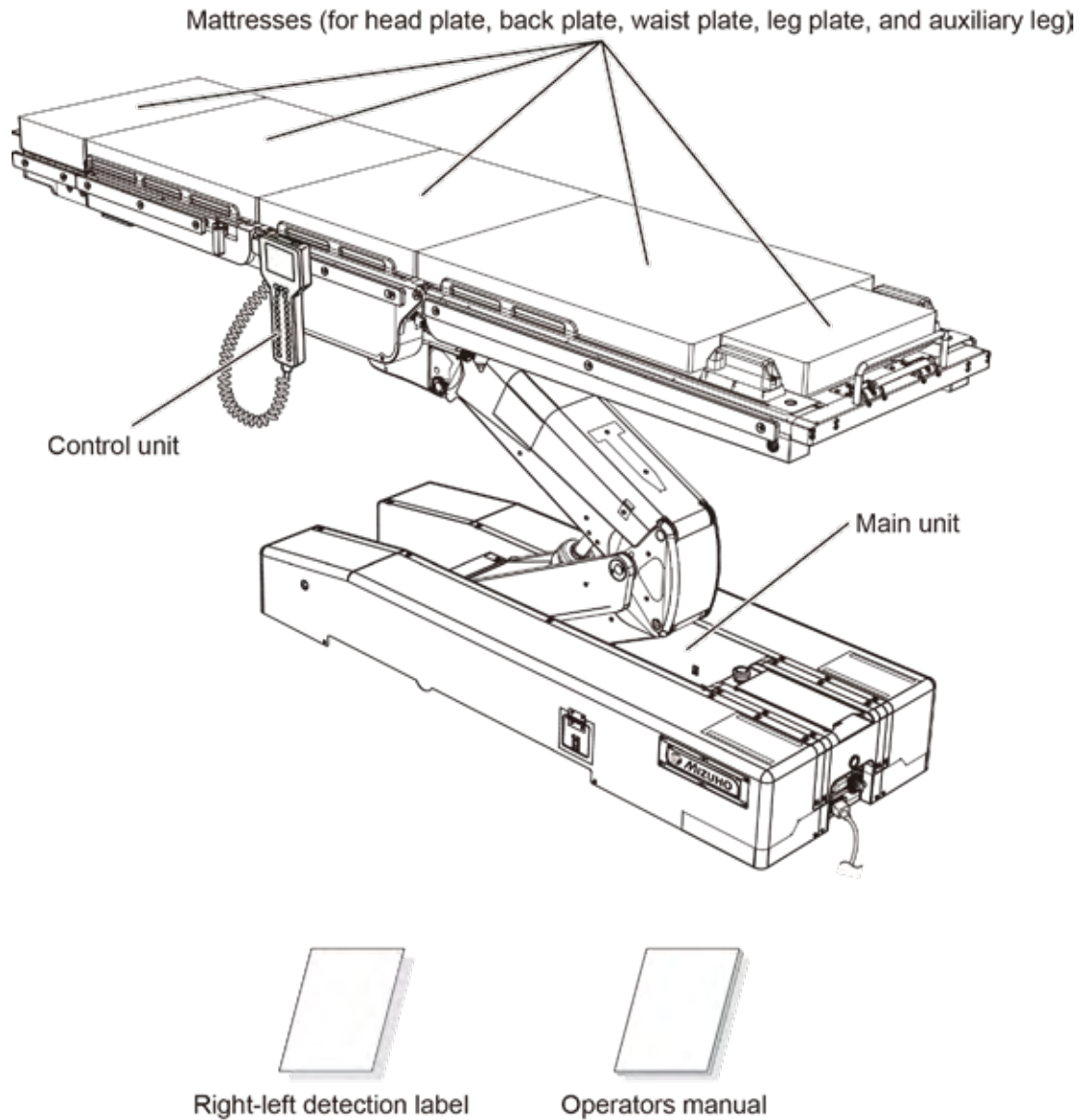

NOTE

The colors, right, and left of the right-left detection label are identical to those on the control unit. Affix the label on the base or any readily visible area.



A-line pole

2. Safety precaution

2.1 Read thoroughly before using

Never perform the following when you use the product.

Otherwise, damage to the operating table, electrical shock, and/or fire may occur.

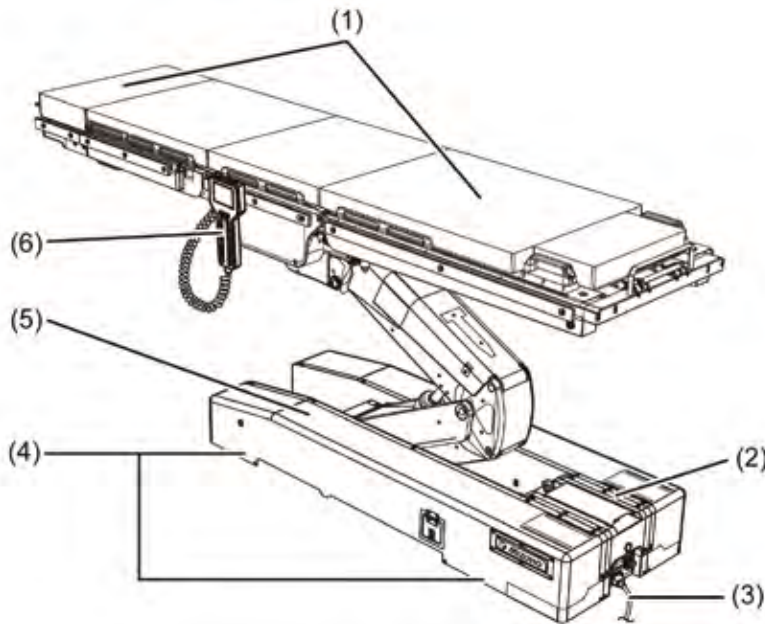

(1) Head plate and leg plate



Do not step or sit on the head plate or the leg plate(s).
The operating table may tip over resulting in injury.

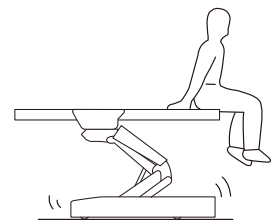

- Before lowering the table or placing it in a reverse Trendelenburg position, check if there are any devices under the leg plates.
If the leg plates come in contact with devices that are to be subjected to excessive force, the leg plate insertion shaft may be damaged.
- When the operating table is put into the Trendelenburg or the back plate/tabletop is moved down with any accessory such as a head frame attached, do not operate the table until the accessory contacts with the floor. It may get damaged.

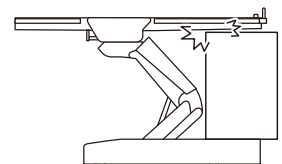

(2) Touch panel



CAUTION

- Do not push the touch panel by any sharps such as a pen and a screw driver. The touch panel may get damaged.
- Do not apply great impact or pressure to the touch panel. The touch panel may get damaged.
- Do not use organic solvents such as paint thinner to wipe the display and the protective cover. They may get damaged.
To wipe the display and the protective cover, use a natural detergent diluted with water.
- The touch panel does not accept simultaneous multiple-key pressing and flicking operations. To operate the operating table using the touch panel, press the button one by one.

(3) Power cord



WARNING

- Do not place any heavy objects on the power cord.
- Do not roll over the power cord with a casted device.
- Do not forcibly pull on the power cord.
- Do not place any objects in the place where the power cord is to be unplugged from the medical grade outlet, which would obstruct it from being unplugged.

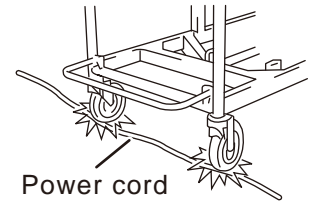

(4) Installation of the operating table



WARNING

- Do not install the operating table on an uneven floor (more than 5°).
- Do not place a pad under the base for raising the operating table.
The operating table may tip over resulting in injury.
- Do not place the operating table within the 5 Gauss line in the MRI room. If not, damages may occur on the patient, operator or the product.

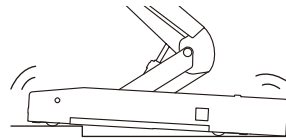

Uneven floor

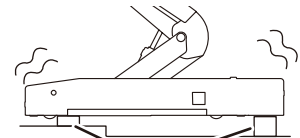

Pad

(5) Base



CAUTION

Do not place any objects on the base. An object may get caught in the sliding cylinder and the operating table may get damaged.

(6) Control unit



CAUTION

- Do not forcibly pull on the control unit cord.
- Do not subject the control unit to strong shocks. The control unit may get damaged.

■ Patient's position during surgical operation



- Make sure to always securely attach the mattresses to the operating table so that they do not come off.
The mattresses may come off, and the patient may get injured.
- Position the patient's body 1 cm (0.39 in) or more away from the metal side rail.
The side rail may produce high temperatures, which may result in a burn injury.

● Positioning the patient

Follow the steps below to position the patient.

1. Attach the mattresses to the tabletop.
2. Put the patient on the mattresses.
3. Position the patient according to the purpose of the surgical operation.



Have the person who operates the operating table to operate it in a position where the emergency stop switch can be immediately pressed, and the patient's condition can constantly observed.

■ Other



- Prohibited
 - Do not disassemble and/or modify the operating table. Otherwise, malfunction may occur.
- Other medical electrical equipment to be used together with the operating table
 - Before use, check that the operating table does not malfunction due to electromagnetic interference from the equipment.
Medical electrical equipment to be used together with the operating table may generate electromagnetic interference, which may result in malfunctioning of the operating table.
 - When using a high-frequency surgical equipment and/or a cardiac defibrillator, refer to their operator's manual provided by the manufacturers. Improper usage may cause the operator and the patient to get burned and/or devices to malfunction.
- Patient position
 - When using the tabletop or accessories (in particular, a fastening band for patient) to secure a patient's body position, always observe the patient's condition.
Neuroparalysis may occur to the patient.
- Allowable load
 - Do not apply a load which exceeds the allowable load*. The operating table may not function, which may result in failures.
* 250kg (551 lbs)
- Preventive maintenance and inspections
 - Make sure to inspect and maintain the operating table before and after use. The operating table may require replacement of the parts due to significant wear, deterioration, and/or breakage depending on the length of service and frequency of use.
 - For preventive maintenance and inspections, contact your distributor or Mizuho directly.
- Antistatic measure
 - Do not use the operating table on floors that do not possess static electricity countermeasures. This may impede surgical operations.

**CAUTION**

- **Devices and accessories used together with this product**
 - Before using other devices or accessories, thoroughly read the instruction manual of the devices and make sure that the operating table is not affected adversely. Before fitting on accessories from third party companies, contact your distributor or Mizuho. Some accessories cannot be fitted on.
 - When the MRI-compatible head frame is used, use the dedicated back plate mattress.
 - While operating the operating table, check the position of other devices or the accessories used with them. They may come in contact with each other during the operation, operating table, devices, and/or accessories may get damaged.
 - For hygiene, be sure to use sterile drapes on the areas on this product where the patient comes into contact with it.
- **Cleaning and disinfection**
 - After using the operating table, make sure to follow the steps below to clean up and disinfect the operating table.
 1. Turn off the power and disconnect the power cord from the medical grade outlet.
 2. Detach all the mattresses from the operating table.
 3. Use a lint-free cloth soaked with proper volume of disinfectant to wipe off the upper, side, and back side of the mattresses.
 4. As with step 3, disinfect the surfaces of the tables and side rails.
 5. Wipe off the operating table with a clean dry cloth 15 minutes after disinfecting it.
 - Make sure to use Mizuho authorized disinfectants. The disinfectants are as shown below.
 - Sodium hypochlorite 0.1% (halogen containing compound)
 - Hypo Alcohol (iodine decolorant color removing agent)
 - Chlorhexidine (chlorhexidine gluconate 0.5%)
 - Benzalkonium chloride (invert soap 10%)
 - Povidone iodine
 - Ethanol 80%
 - Oxydol (hydrogen peroxide)
 - Saline
 - Isopropyl alcohol (IPA) 99.5%



CAUTION

- **Moving and transporting**
 - Follow the procedures below to move the operating table.
 - * Before moving the operating table, disinfect the entire operating table in order to prevent infection.
 1. Turn off the power and disconnect the power cord from the medical grade outlet.
 2. Check if the handles and levers are in fixed positions, and each section is fixed firmly.
 3. Unlock the brakes, and move the operating table.
 - The operating table should be transported with the following conditions met.
 - Disinfect the entire operating table before transporting it.
 - Take measures to prevent it from tipping over, such as lowering the tabletop to the bottom position.
 - Actuate the brake.
 - Suitably position cushioning on the product to prevent it from getting damaged during transport.
 - Store the product in a container so that it does not get exposed to dust, and the weather.
 - **Disposal cautions**
 - Always follow the local country regulation in disposing the operating table.
-

2.2 Labeling

The operating table is labeled at the locations shown as below.
Before use, make sure to understand the contents of the labels.

Warning and Caution labels

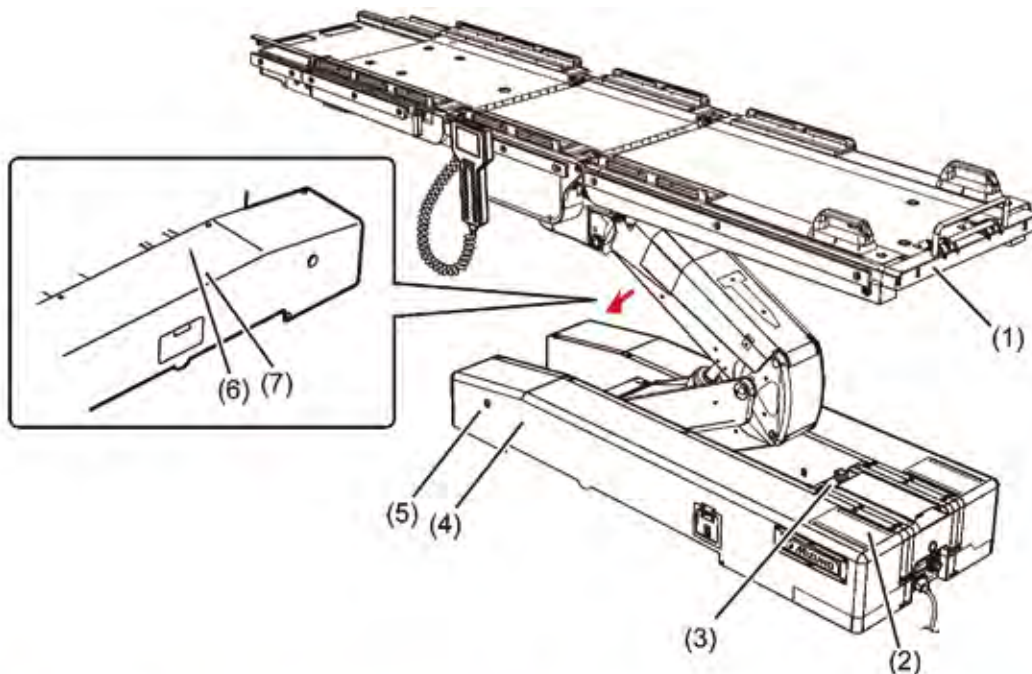

(1) C657362 □

⚠ WARNING Do not install this operating table in 5 gauss line.	⚠ MISE EN GARDE N'installez pas ce table d'opération dans 5 gauss ligne.
⚠ CAUTION Do not hang any object on the unlocking lever.	⚠ ATTENTION Ne suspendez aucun objet sur le levier de déverrouillage.

(2) C657332 □

⚠ CAUTION ● KEEP THE PROTECTIVE COVER CLOSED ALWAYS, EXCEPT WHEN OPERATING THE TOUCH PANEL.	⚠ ATTENTION ● MAINTENEZ TOUJOURS LE CACHE PROTECTEUR FERMÉ, EXCEPTÉ LORS DE L'UTILISATION DE L'ÉCRAN TACTILE.
⚠ ● AVOID TOUCHING A SHARP OBJECT OR EXERTING UNOUE STRESS ON THE SURFACE OF TOUCH PANEL.	⚠ ● ÉVITEZ DE TOUCHER LA SURFACE DE L'ÉCRAN TACTILE AVEC UN OBJET POINTU OU D'EXERCER UNE PRESSION EXCESSIVE SUR CETTE SURFACE.

(3) C657312 □



(4) C656740 □

⚠ WARNING TO REDUCE THE RISK OF ELECTRIC SHOCK, DO NOT REMOVE COVER OR BACK.	⚠ MISE EN GARDE NE PAS RETIRER LE COUVERCLE OU LA FACE ARRIÈRE AFIN DE RÉDUIRE LE RISQUE D'ÉLECTROCUTION.
ⓘ REFER SERVICING TO QUALIFIED SERVICE PERSONNEL.	ⓘ CONFIER L'ENTRETIEN AU PERSONNEL DE SERVICE QUALIFIÉ.
📄 REFER TO ACCOMPANYING DOCUMENTS.	📄 SE RÉFÉRER AUX DOCUMENTS D'ACCOMPAGNEMENT.

(5) C657331 □

⚠ DANGER ● POWER STILL PRESENT WITH MAIN SWITCH IN OFF POSITION. LOCK OUT UPSTREAM SUPPLY BEFORE ENTERING FOR SERVICE.	⚠ DANGER ● L'ALIMENTATION EST TOUJOURS PRÉSENTE LORSQUE L'INTERRUPTEUR PRINCIPAL EST SUR LA POSITION OFF. VERROUILLER L'ALIMENTATION EN AMONT AVANT D'ENTRER POUR TOUTE INTERVENTION.
ⓘ ● POSSIBLE EXPLOSION HAZARD IF USED IN THE PRESENCE OF FLAMMABLE ANESTHETICS.	ⓘ ● POSSIBILITÉ D'EXPLOSION EN CAS D'UTILISATION EN PRÉSENCE D'ANESTHÉSIOSES INFLAMMABLES.
⚠ ● DISCONNECT SUPPLY BEFORE SERVICING.	⚠ ● COUPER L'ALIMENTATION AVANT L'ENTRETIEN ET LE DÉPANNAGE.

(6) C655803 □

⚠ CAUTION ● THE AUXILIARY SWITCH IS INTENDED TO BE USED WHEN THE CONTROL UNIT IS DEFECTIVE. USE THE CONTROL UNIT WHENEVER IT IS IN NORMAL CONDITION. BECAUSE THE AUXILIARY SWITCH HAS NO FUNCTION TO RESTRICT THE OPERATION OF THE TABLE, THE TABLE MAY BE DAMAGED WHEN IT IS OPERATED WITH THE AUXILIARY SWITCH. ● WHEN OPERATING THE TABLE WITH THE AUXILIARY SWITCH, BE SURE TO WATCH THE MOVEMENT OF THE TABLETOP CONTINUOUSLY. ● IF THE TABLETOP SHOULD TOUCH ANYTHING OR GET DAMAGED IN ANY DURING THE OPERATION, STOP OPERATING THE TABLE IMMEDIATELY.

(7) C657333 □

⚠ ATTENTION ● LE COMMUTATEUR DE SECOURS EST PRÉVU POUR ÊTRE UTILISÉ LORSQUE LE BOITIER DE COMMANDE EST DÉFECTUEUX. UTILISEZ TOUJOURS LE BOITIER DE COMMANDE DES LORS QU'IL EST EN ÉTAT NORMAL. LE COMMUTATEUR DE SECOURS N'AVANT AUCUNE FONCTION LUI PERMETTANT DE LIMITER LE FONCTIONNEMENT DE LA TABLE, CELLE-CI PEUT ÊTRE ENDOMMAGÉE LORSQU'ELLE EST UTILISÉE AVEC LE COMMUTATEUR DE SECOURS. ● LORSQUE VOUS UTILISEZ LA TABLE AVEC LE COMMUTATEUR DE SECOURS, ASSUREZ-VOUS DE CONTINUËLLEMENT SURVEILLER LE MOUVEMENT DU PLATEAU. ● SI LE PLATEAU VIENT À TOUCHER QUELQUE CHOSE OU EST ENDOMMAGÉ D'UNE QUELCONQUE MANIÈRE DURANT L'OPÉRATION, CÉSSEZ IMMÉDIATEMENT D'UTILISER LA TABLE.

Other labels (1/2)

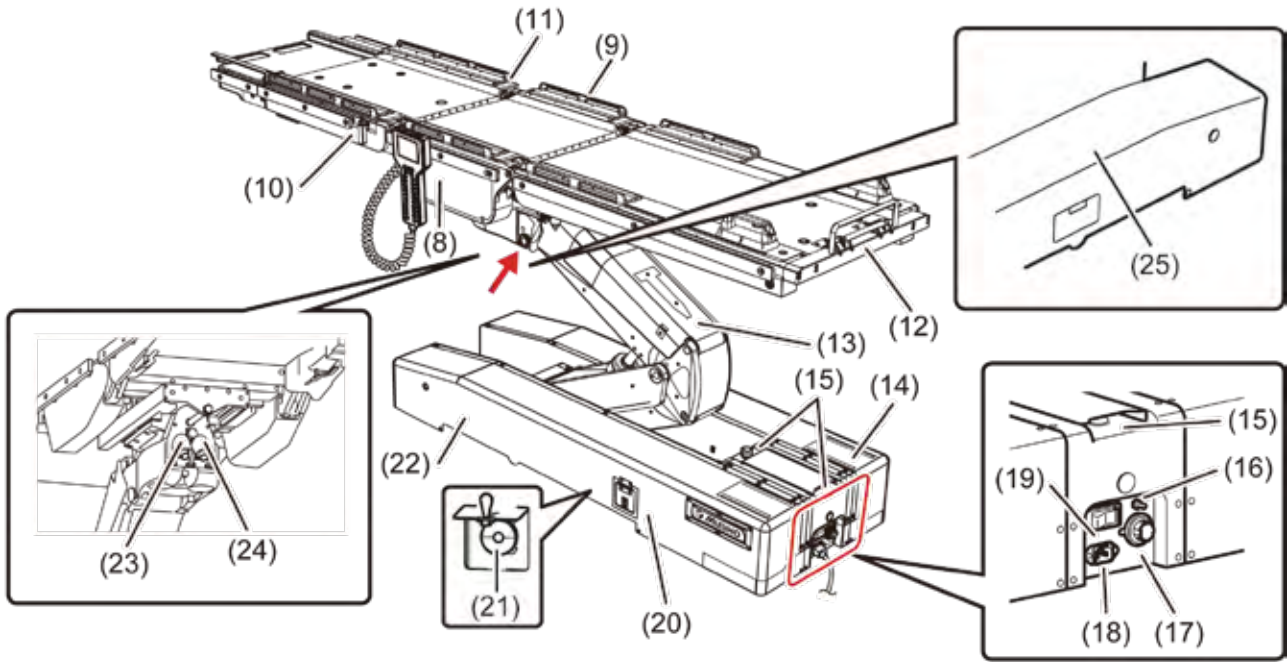

(8) C657358



(9) C657359



(10) C657363



(11) C657364



(12) C657365



(13) C655683

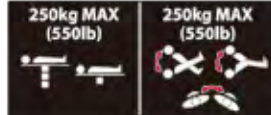

(14) C630006 (Mg-T)



C630006 (NMg-P)



(15) C657313



(16) C657309



(17) C657308



(18) C657307



(19) C657306



(20) C657318



(21) C655711



(22) C656741

NOTE	REMARQUE
GROUNDING RELIABILITY CAN ONLY BE ACHIEVED WHEN THE EQUIPMENT IS CONNECTED TO AN EQUIVALENT RECEPTACLE MARKED "HOSPITAL ONLY" OR "HOSPITAL GRADE".	LA FIABILITÉ DE MISE À LA TERRE NE PEUT ÊTRE OBTENUE QUE LORSQUE L'ÉQUIPEMENT EST CONNECTÉ À UNE PRISE ÉQUIVALENTE REPÉRÉE "HÔPITAL UNIQUEMENT" OU "QUALITÉ HÔPITAL".

(23) C657311



(24) C657310



(25) C657341



Other labels (2/2)

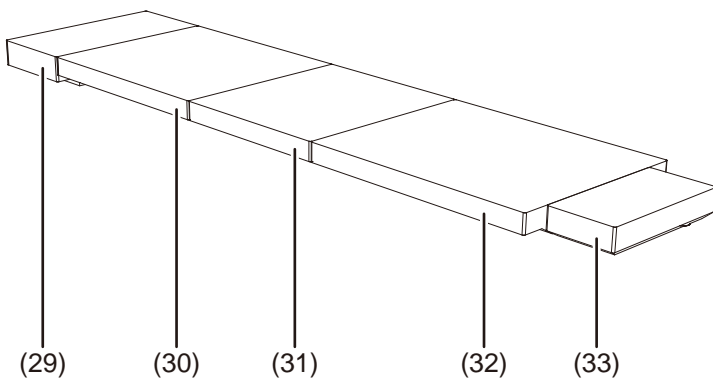
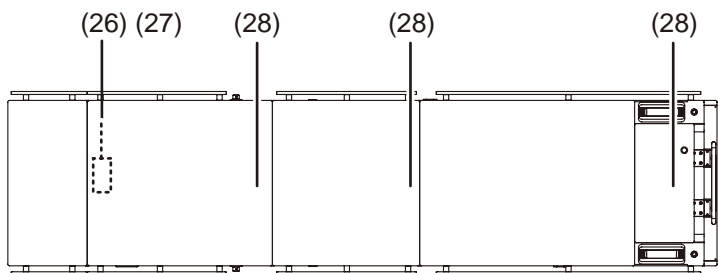

(26) C657360□ (Mg-T)



(27) C657361□ (Mg-P)



(28) C653620□



(29) PIN 722J5M1



(30) PIN 722J6M1



(31) PIN 722J7M1















(32) PIN 722J8M3



(33) PIN 722J8M2



■ Labeling list

Symbol	Description	Label no.
	Indicates a possibility of injury or even death if operates the table without following the warning.	(2) (3) (5) (6) (7)
	General prohibition sign	(2) (4)
	General mandatory action sign.	(2) (4) (5)
	Emergency stop	(3)
	Refer to the operators manual	(4) (14) (15)
	Indicates AC power supply.	(14) (18)
IPX4	Enclosure Class (Splash-proof)	(14)
SN	Serial number	(14)
REF	Catalogue Number	(14)
	Indicates waste disposal information.	(14)
	Authorized representative in the European Community	(14)
	Manufacturer	(14) (29) (30) (31) (32) (33)
	Equalization terminal	(16)
	USB	(17)
	POWER ON	(18)
○	POWER OFF	(18)
	Indicates protection against electric shock and defibrillator (Class B).	(28)
	Defibrillation - proof Type B applied part	(29)(30) (31) (32) (33)

3. Component identification

3.1 Main unit

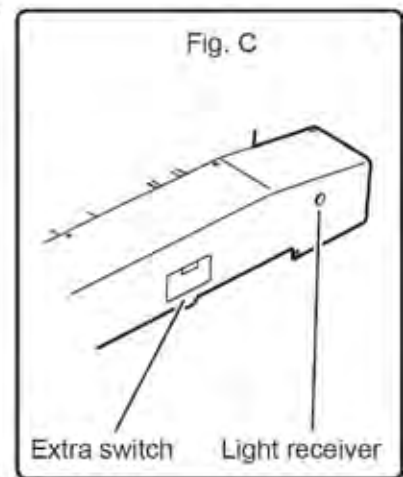
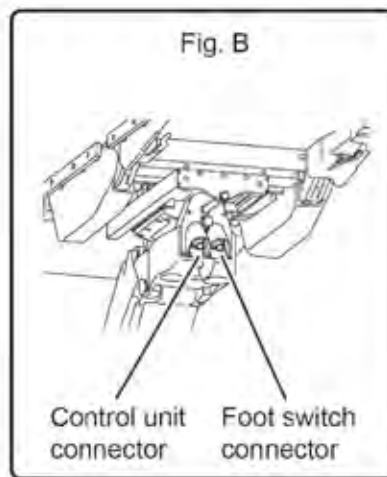
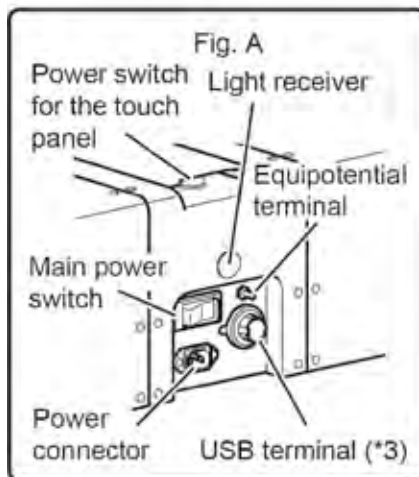
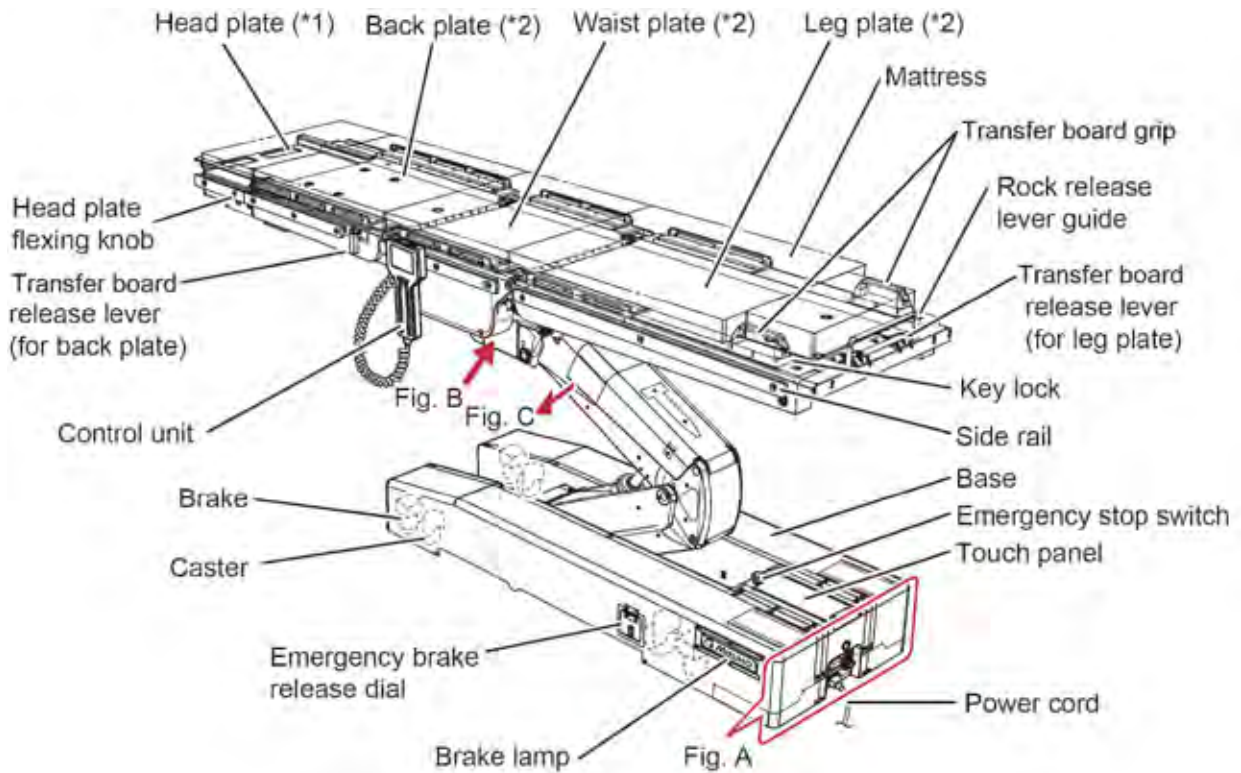

*1: The head plate is detachable.

*2: The transfer board rests on each of the back, waist, and leg plates.

*3: The USB terminal is intended to be used for maintenance. Do not connect a device such as a personal computer to the USB terminal.

3.2 Touch panel

TOP PAGE screen

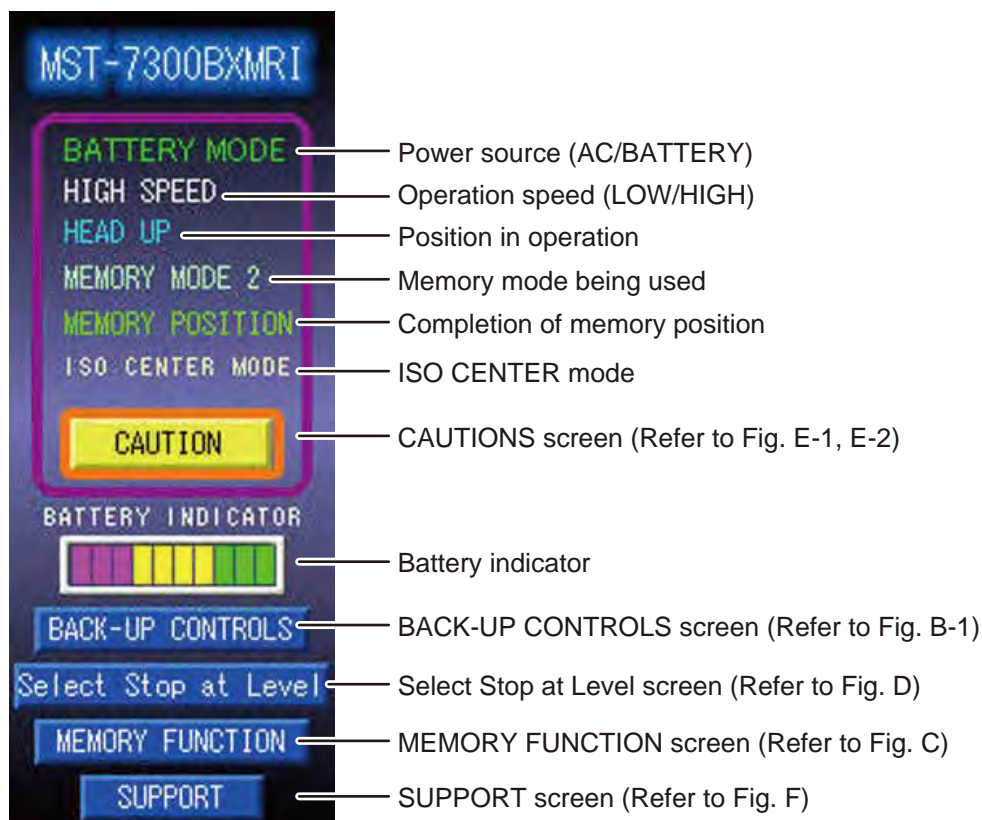

Fig. A

BACK-UP CONTROLS screen (1/2)

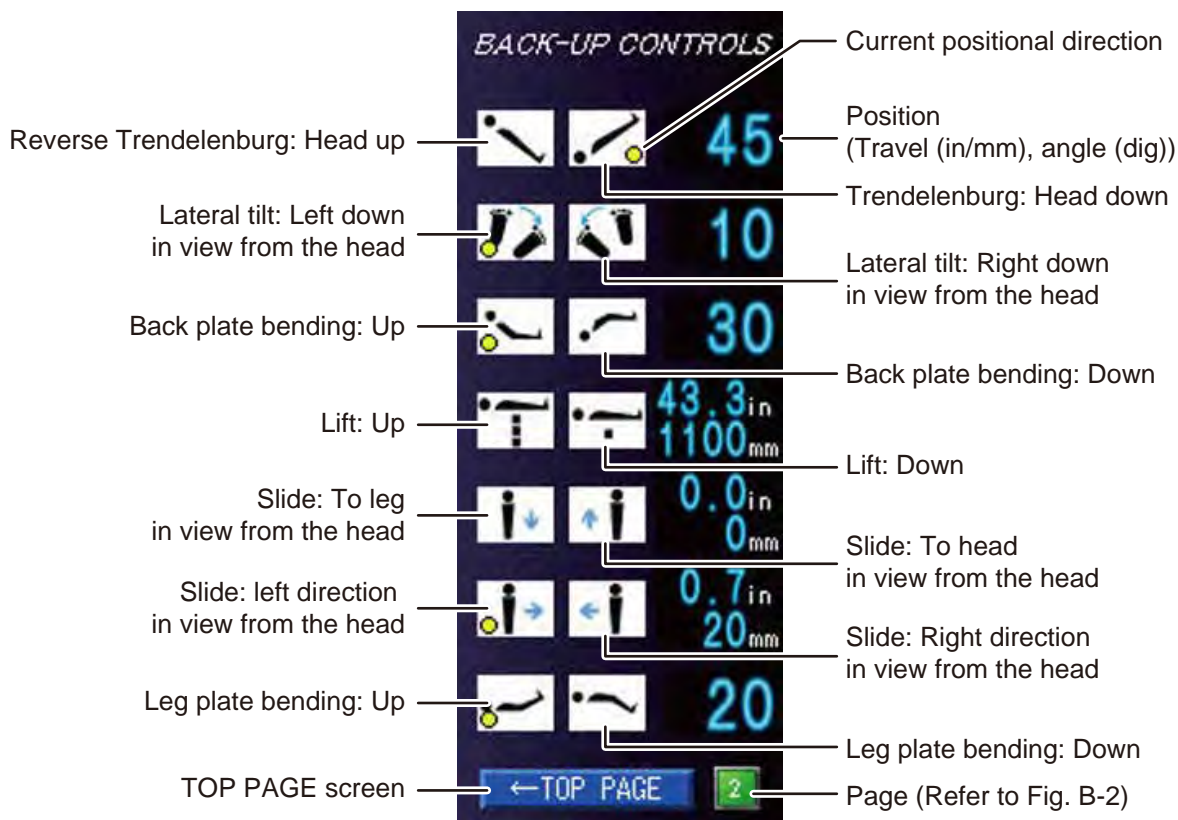

Fig. B-1

■ BACK-UP CONTROLS screen (2/2)

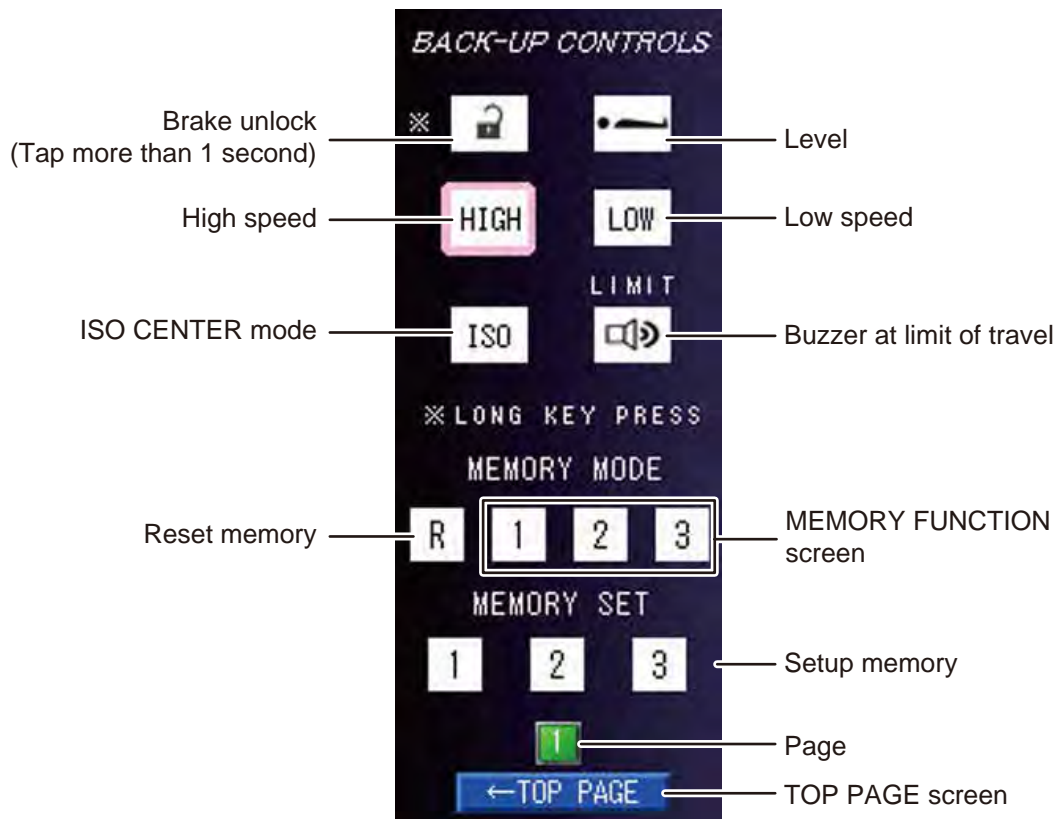

Fig. B-2

■ MEMORY FUNCTION screen

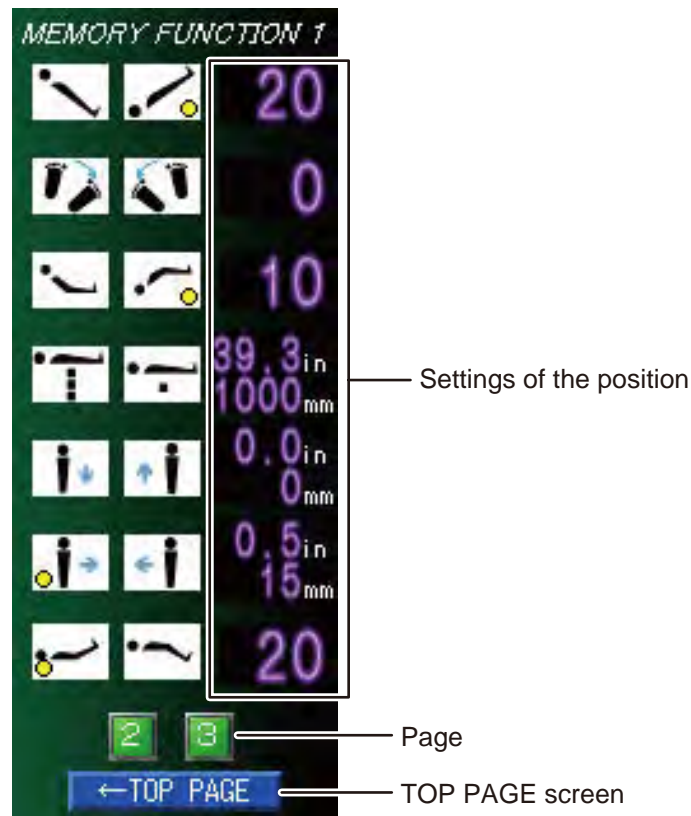

Fig. C

NOTE

For the details of the MEMORY FUNCTION, refer to Page 49.

■ Select Stop at Level screen

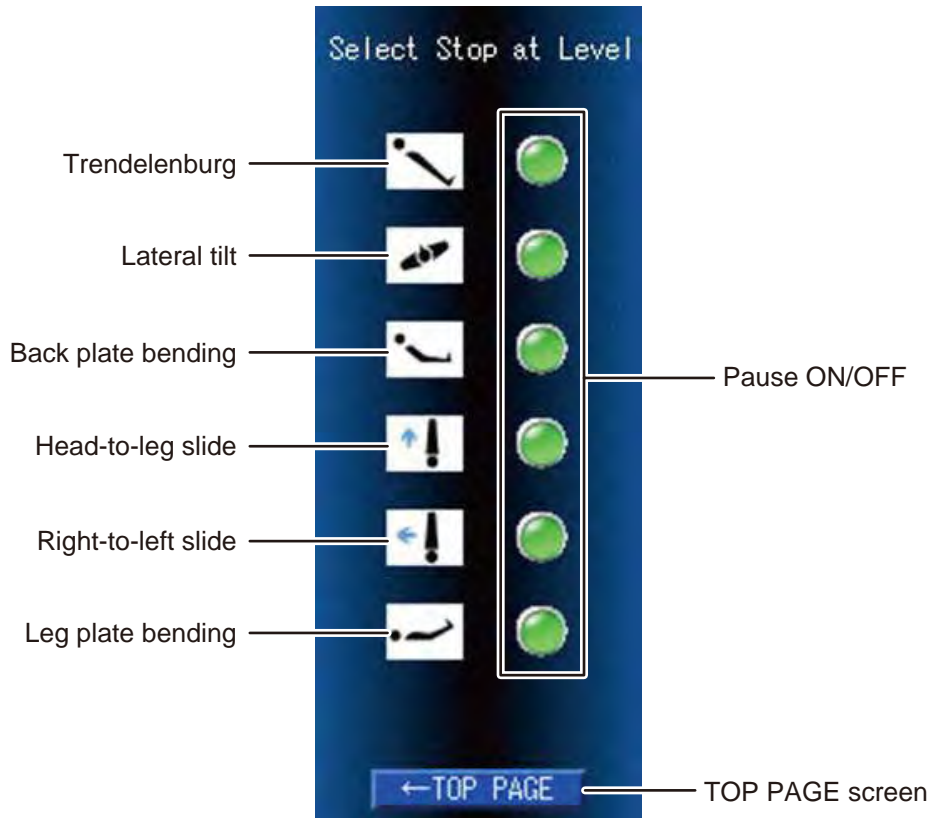

Fig. D

NOTE

- With the default setting, all functions are set to ON.
- For the details of the Select Stop at Level screen, refer to Page 30.

■ CAUTION screen

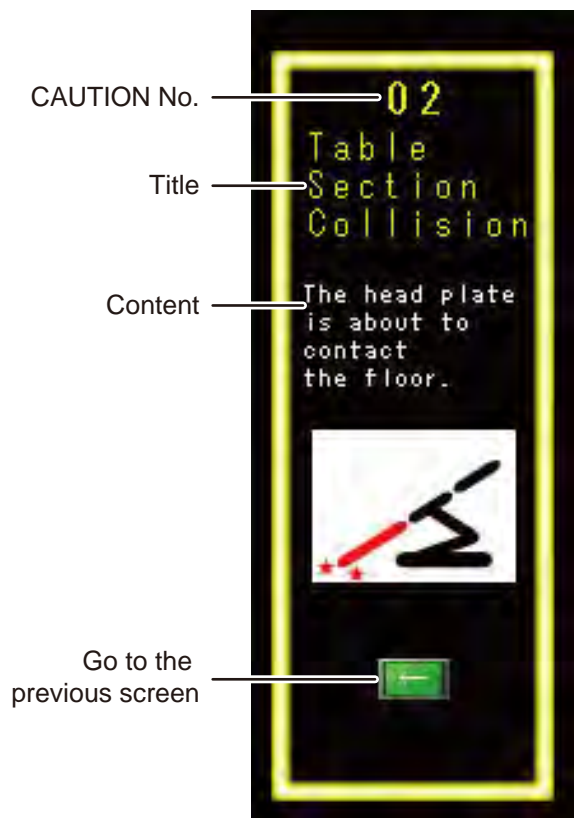

Fig. E-1

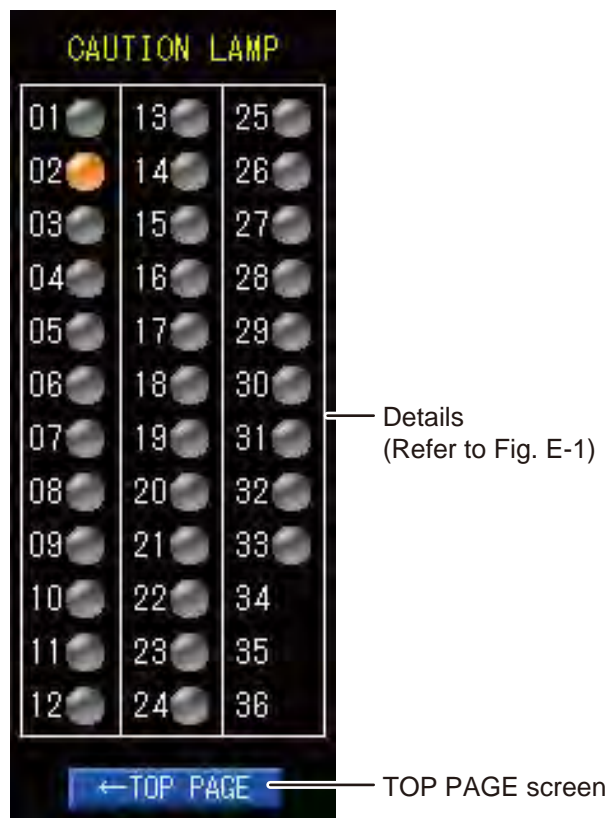

Fig. E-2

NOTE

- To prevent damages, the operating table may stop during operation and a caution/warning screen such as in Fig. E-1 appears on the touch panel. For specific recovery procedures after the operating table stopped, refer to Page 73.
- Fig. E-2 appears, if you click CAUTION in Fig. A while any caution or warning has occurred. When one caution/ warning occurred, the screen of Fig.E-1 appears.

■ SUPPORT screen

3

Component identification

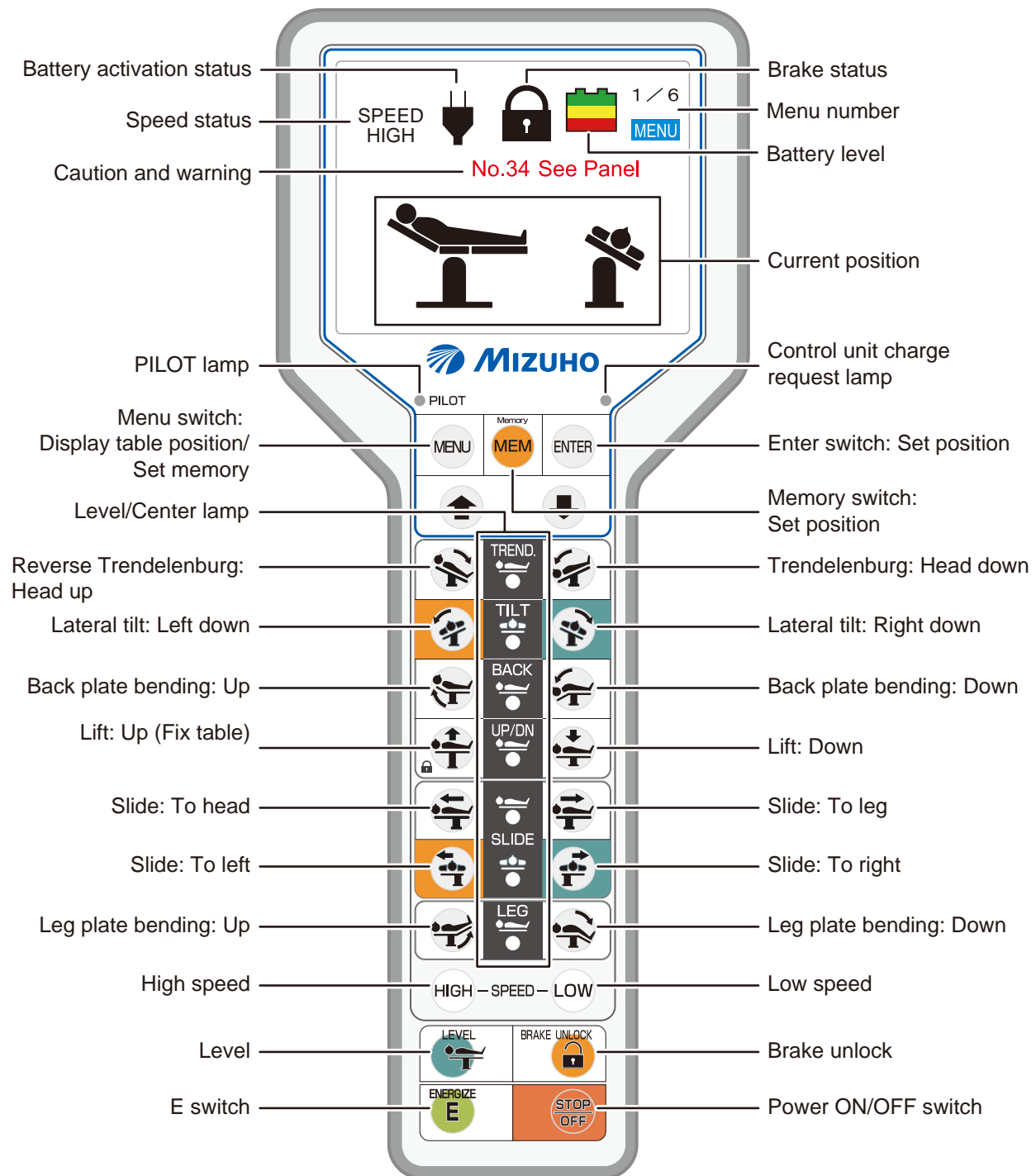

Fig. F

NOTE

Please contact the dealer in the list for any repair or maintenance.

3.3 Control unit



NOTE

- The switches other than the E switch continue to function while being pressed.
- If **E** is pressed, function switches light up for 3 seconds. Pressing any function switch while they are lighting up activates the function of the switch, and the PILOT lamp lights up. **E** The function does not work even if you pressed the function switch before pressing **E**.
- **HIGH** and **LOW** light up when respective operation speeds are reached.
- The control unit charge request lamp blinks when charging is required and lights up while charging.
- The level/center lamp lights up when the table top is at the level or center position of respective operations.
- To prevent damages, the operating table may stop during operation with a message shown on the control unit. For specific recovery procedures after the operating table stopped, refer to Page 73.
- When the control unit is in a use with no wire, nothing appears on the monitor.
- While the battery is being used, the power is turned off after 3 minutes.

3.4 Foot switch (option)

3

Component identification

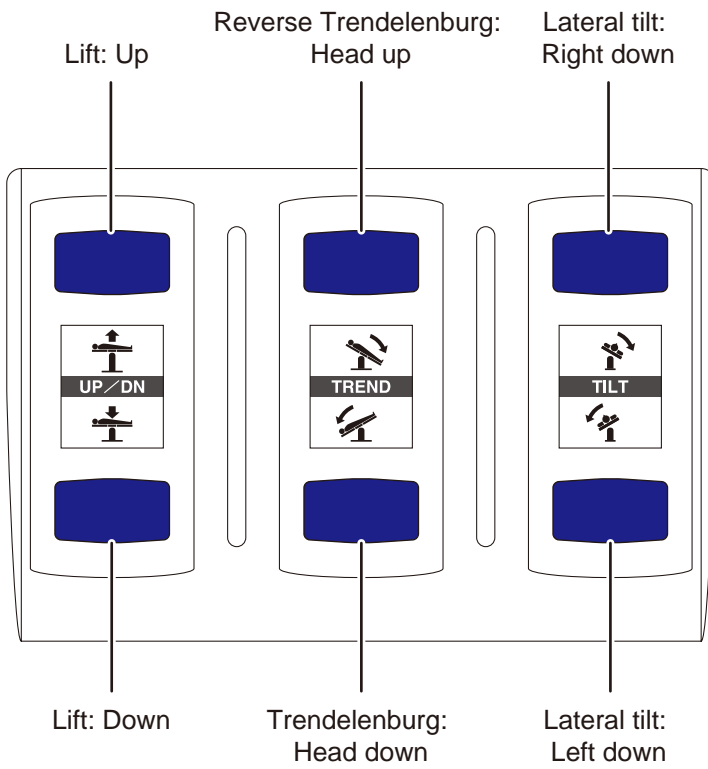

4. Installation

4.1 Installation

This product requires the installation space shown as below.

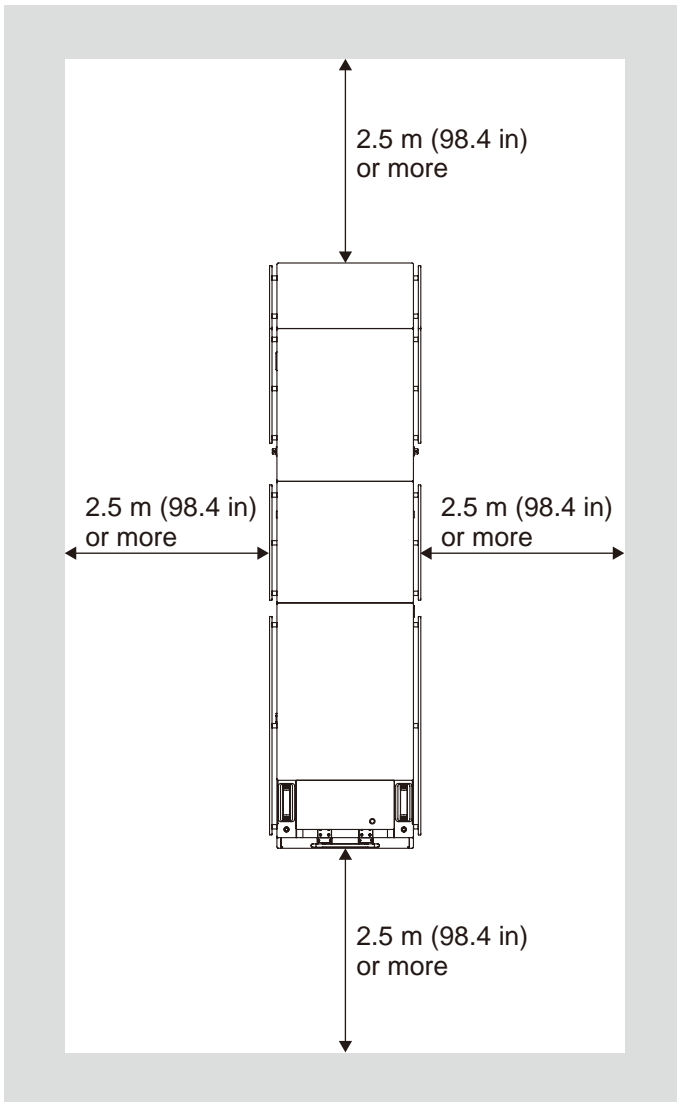

CAUTION When this product is used with the power cord disconnected, use the equipotential wire to ground the equipotential terminal to the medical grounding terminals. Prepare the equipotential wire yourself.

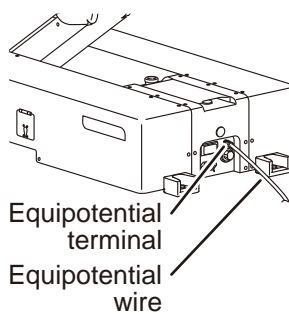

1. Move this product to a flat place to install it.

4.2 Connecting/Disconnecting the control unit

■ Attaching the control unit

1. Align the connector with the guide and insert it into the receptacle properly.

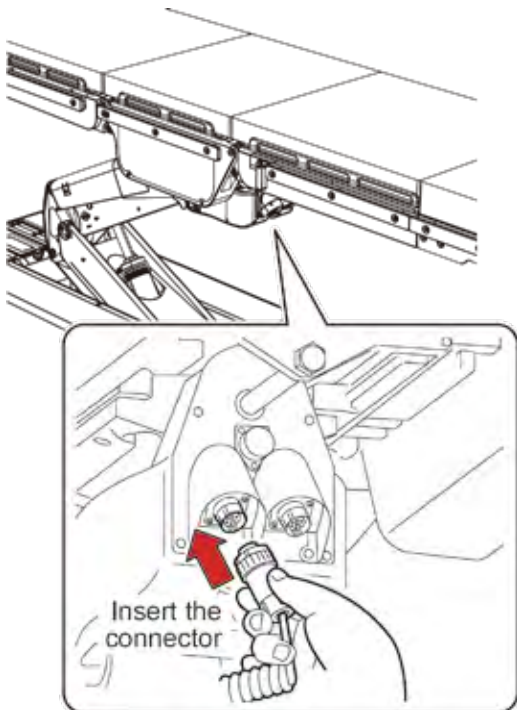

■ Detaching the control unit

When you detach the control unit, detach the connector from the receptacle.

1. Turn the connector ring in the direction of the arrow until it stops.
2. Pull out the connector.

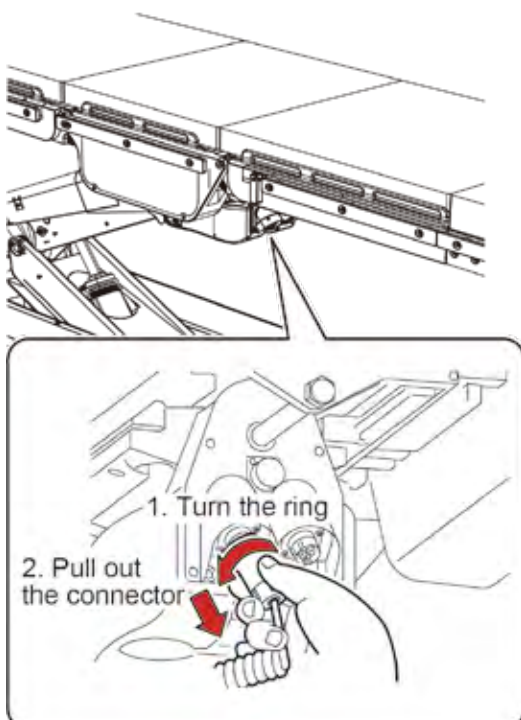

■ Using the control unit wirelessly

The control unit can be detached from the main unit and used wirelessly.

● Putting the control unit to the wireless control status

1. Disconnect the control unit connector from the control unit.



Hold the connector body to disconnect it. Holding the cord to disconnect the connector may cause breaking of the cord.

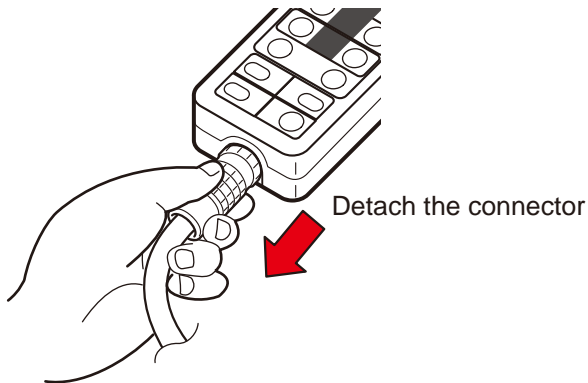

NOTE

- While being used wirelessly, the control unit works on the internal battery.
- While the control unit is being used wirelessly, nothing appears on the monitor screen.
- It is normal for "No.11" and "No.31" to appear on the display screen of the touch panel when the control unit is disconnected from the main unit.

● Operation

1. Aim the control unit toward the light receiver of the operating table and operate the control unit.

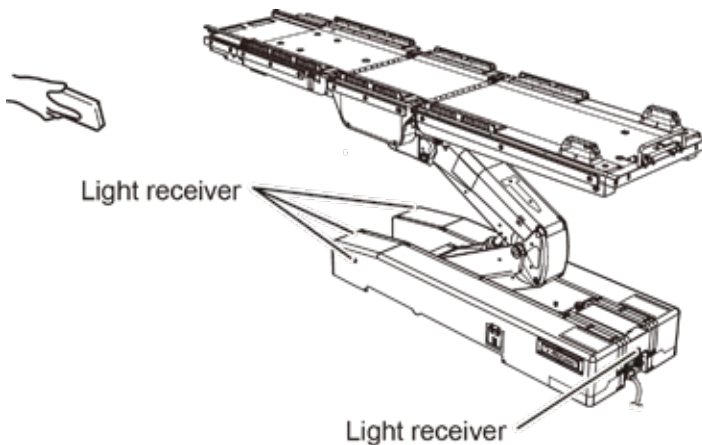

● Charging

The control unit cannot be used wirelessly when the battery level is low. If the control unit charge request lamp at the upper right of the control unit lit on, connect the control unit with the cord and immediately charge the control unit.

Use the dedicated AC adapter (optional) to charge the control unit from your outlet.



NOTE

The battery of the control unit can be recharged only when the battery is decreased in the power level and the battery level lamp blinks.

● Connecting the control unit by cable

1. Align the connector with the guide and insert it into the receptacle properly.

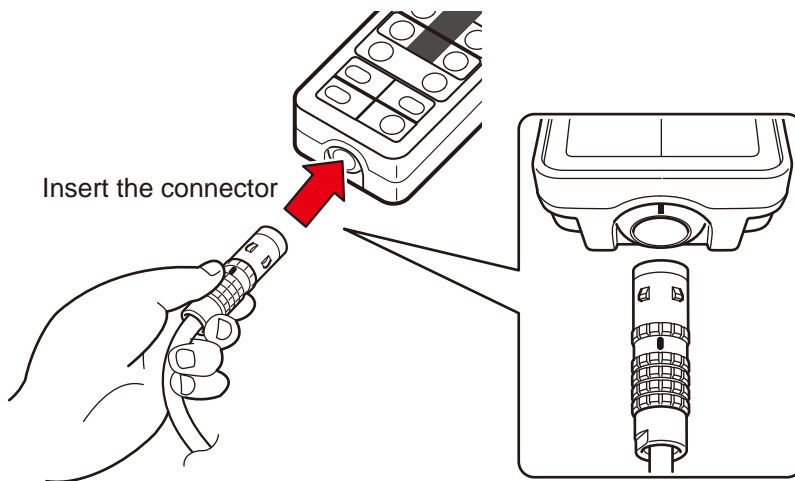

4.3 Turning on/off the power

This procedure is different between the powers from the medical grade wall outlet and the battery.



- Connect the product to the power source provided with the protective grounding to prevent the risk of an electrical shock.
- Make sure to use the dedicated power cord with the "MIZUHO" logo.
- Before inserting the power cord into the power source connector, check that the power source connector does not have any fluid in it nor is dusty.
- To shut down the power completely, pull out the power cord from the medical grade outlet.

■ When the medical grade wall outlet is used

● Turning on the power

1. Connect the power connector and the medical grade outlet with the power cord, and turn on the power switch.

The power switch green lights up, "AC MODE" appears on the touch panel, and  appears on the display of the control unit.

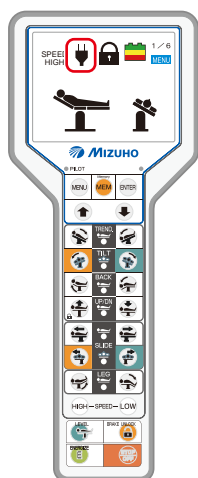
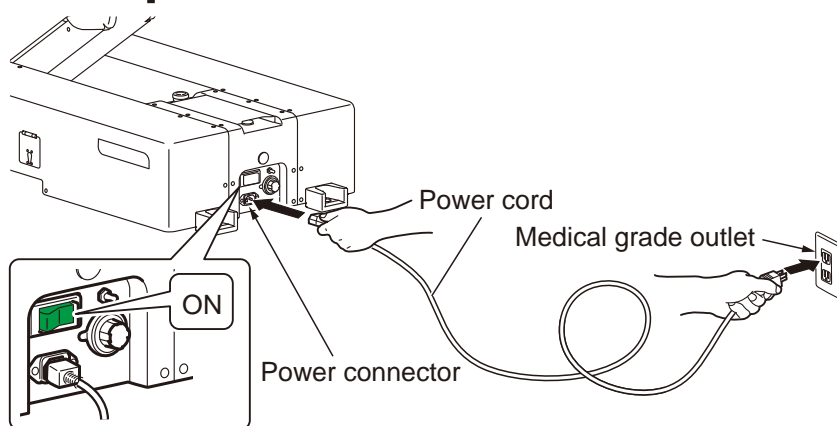

NOTE

In an emergency or when turning off the power completely, disconnect the power cord from the medical grade outlet.

● Turning off the power

1. Turn off the power switch on the base.

The power switch green lights off, and  disappears on the display of the control unit.

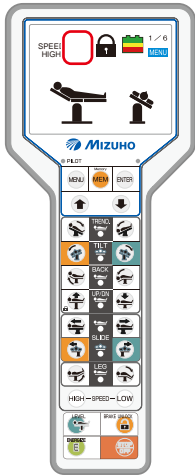
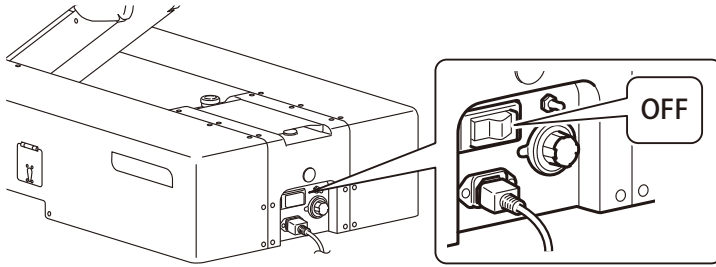

2. Press of the control unit.

The touch panel and monitor light off.

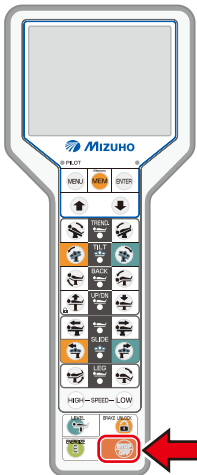

■ When the battery is used

● Turning on the power

1. Press **E** on the control unit with the power cord disconnected from the power connector.

"BATTERY MODE" appears on the touch panel, and  appears on the display of the control unit.

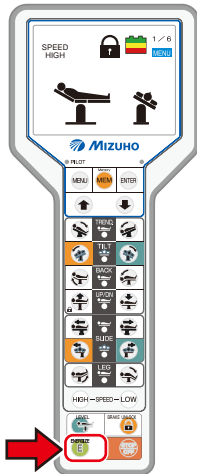
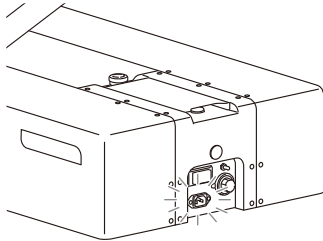

NOTE

- During use with the battery power, the power is automatically turned off if no operation is performed for 3 minutes or more.
- To turn on the power, press **E** on the control unit or the blue button below the touch

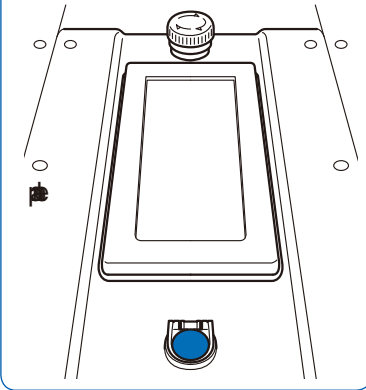

2. Check the display of the control unit.

The battery needs to be charged if the battery level icon turns to  on the monitor screen.

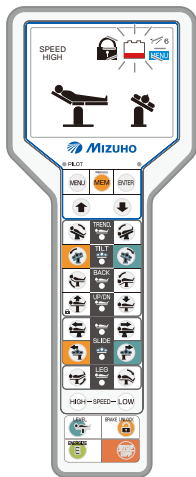

NOTE

You can also use the battery indicator of the touch panel to check the charging status. When the battery indicator lights up only red, battery charging is necessary.

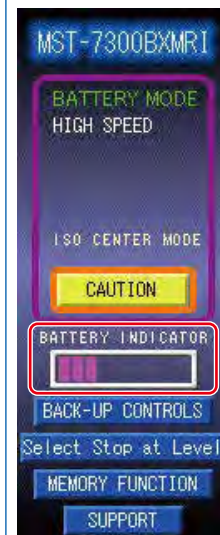

● Turning off the power

1. Press  on the control unit with the power cord disconnected from the power connector.

The touch panel and monitor light off.

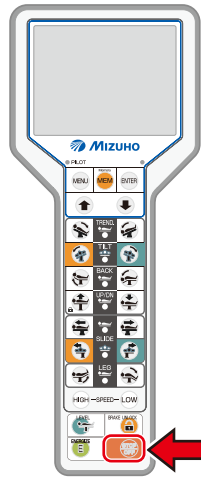
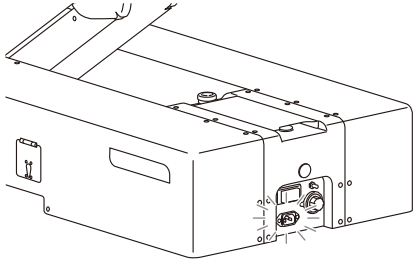

4.4 Charging the battery

Make sure to charge the battery when initially using the purchased product, or when it has not been used for a long time.

1. Connect the power connector and the medical grade outlet with the power cord, and turn on the power switch.

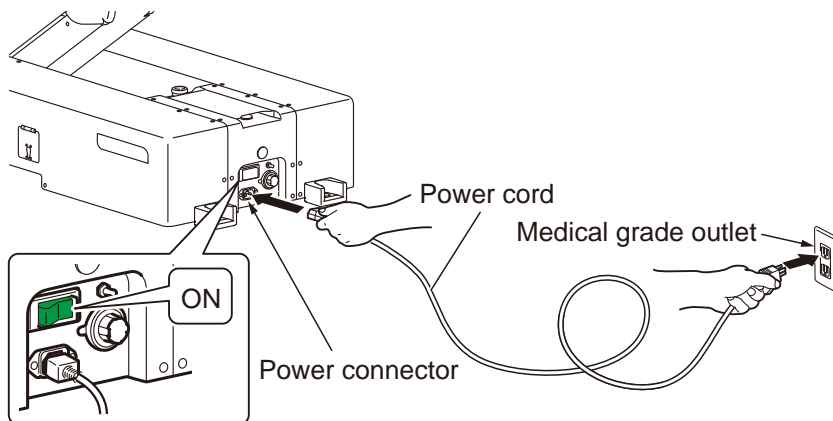

Battery charging starts.

While charging, "CHARGE" appears on the battery indicator of the touch panel.

If the battery indicator changed to "FULL BATTERY," the charging is completed.



NOTE

- The battery naturally discharges itself when it is not being used and is being stored. Make sure to charge the battery before use.
- While the battery is being charged, you can operate the operating table.
- If the battery level on the monitor of the control unit is red only, or the battery indicator on the touch panel is red only, immediately charge the battery. When the battery is discharged, only the AC power is available.
- The operating table battery life-span is about 2 years. Once it reaches its life-span, request your distributor or Mizuho for a battery replacement.
- The life-span for the battery varies greatly depending on operating conditions. The battery could degrade quicker if charging and discharging the battery are repeated frequently after using the operating table for short operations.
- It is recommended that you charge the battery once a week on weekends, since it takes 20 hours to fully charge the battery.
- If "FULL BATTERY" does not appear on the battery indicator or the battery is discharged soon even after charging, the battery may be degraded. Request repairs from your distributor or Mizuho.

5. Settings

5.1 Changing the temporary stop at the center position

With the default setting, the operating table will stop once at the center position if the table is moved toward an opposite direction. You can set whether the operating table stops or not at the center position.

1. Show the "TOP PAGE" screen of the touch panel.
2. Tap "Select Stop at Level".



The "Select Stop at Level" screen appears.

3. Tap the lamp of a function that you want to cancel the temporary stop of the operation at the center position.

The lamp of the function you tapped disappears in gray out, and the operating table is set so as not to stop at the center position.

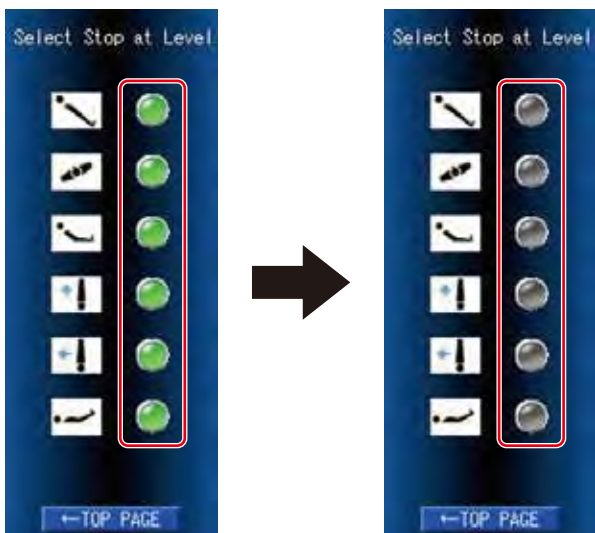

NOTE

- For the procedure to show the touch panel, refer to Page 36.
- For the procedure to show the "TOP PAGE" screen of the touch panel, refer to Page 14.

NOTE

Tapping the lamp again makes the lamp green, which sets the operating table so as to stop at the center position.

5.2 Changing the movement of the lateral tilt

In the initial condition, the tabletop slides laterally so that is not displaced from the center of the main unit (ISO CENTER mode). You can set whether the ISO CENTER mode is activated or deactivated.

● Not ISO CENTER mode

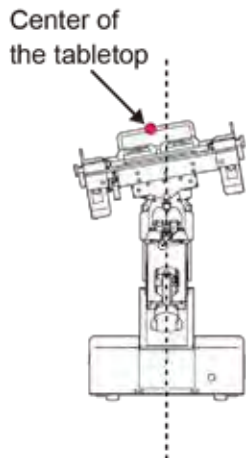

● ISO CENTER mode

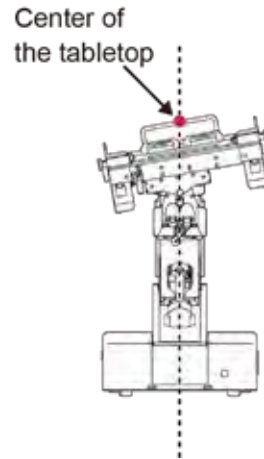

1. Show the "TOP PAGE" screen of the touch panel.
2. Tap "BACK-UP CONTROLS".



The "BACK-UP CONTROLS" screen appears.

NOTE

- For the procedure to show the touch panel, refer to Page 36.
- For the procedure to show the "TOP PAGE" screen of the touch panel, refer to Page 14.

3. Tap "2".



The page changes.

4. Tap "ISO".

The ISO CENTER mode is deactivated.

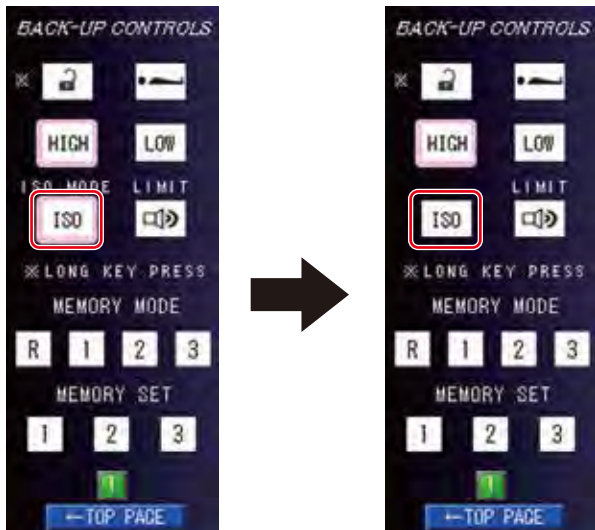

NOTE

- After the ISO CENTER mode was deactivated, "ISO CENTER MODE" disappears on the "TOP PAGE" screen of the touch panel.

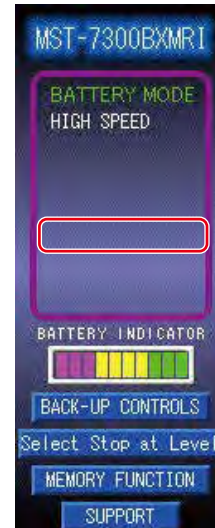

- Tapping "ISO" again activates the ISO CENTER mode.

5.3 Activating buzzer at limit of travel

Buzzer can be activated so as to generate a buzzer sound when the operating table approaches the limit of travel during operation.

1. Show the "TOP PAGE" screen of the touch panel.

2. Tap "BACK-UP CONTROLS".



The "BACK-UP CONTROLS" screen appears.

3. Tap "2".



The page changes.

NOTE

- For the limits of travels, refer to Page 66.
- For the procedure to show the touch panel, refer to Page 36.
- For the procedure to show the "TOP PAGE" screen of the touch panel, refer to Page 14.

4. Tap "LIMIT".

Buzzer at limit of travel is activated.

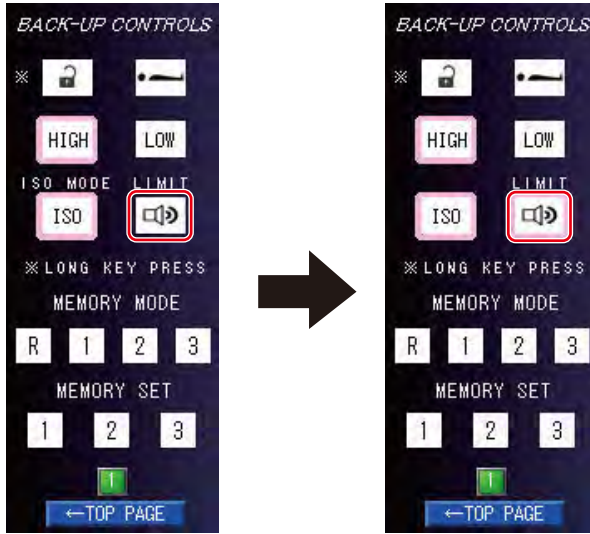

5.4 Switching speed

To finely adjust the movement of the operating table, set the mode to the low speed mode.

■ Switching to the low speed mode

1. Press **E** first and then **LOW**.

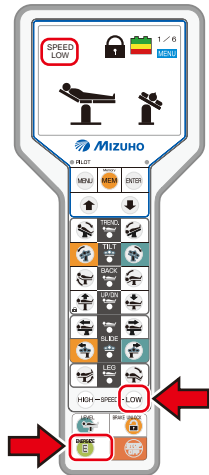

The low speed mode is activated, the back light of **LOW** lights up, and then **SPEED LOW** appears on the monitor.

■ Switching to the high speed mode

1. Press **E** first and then **HIGH**.

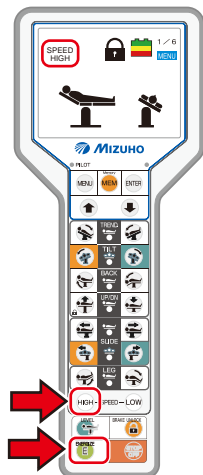

The high speed mode is activated, the back light of **HIGH** lights up, and then **SPEED HIGH** appears on the monitor.

6. Operation

6.1 Display the monitor

When the monitor and the touch panel light off, you can not control the operating table.

If you control the operating table, follow the steps below to show the screen.

1. Press **E**.

After the start up operation completed, the monitor screen and the touch panel light up.

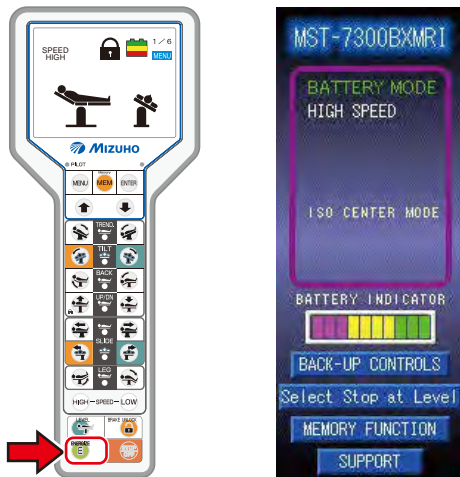

NOTE

The touch panel can be also turned on by pressing the blue button below the touch panel.

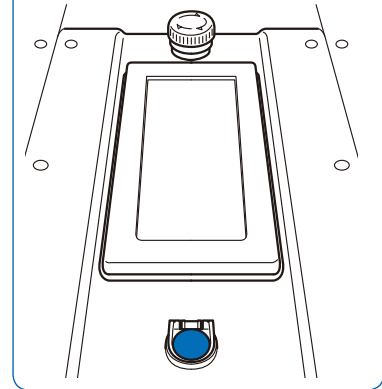

6.2 Operating the emergency stop switch



WARNING

The emergency stop switch must be used only in an emergency.

In an emergency, you can stop operating table from moving by pressing the emergency stop switch.

■ Operating in an emergency

1. Press the emergency stop switch.

The buzzer sounds and the operating table stops.

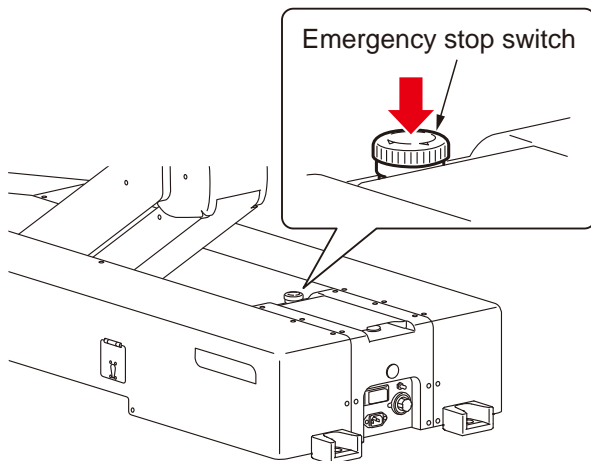

■ Canceling operations

1. After the operating table stops, turn the emergency stop switch in the direction of the arrow to cancel the emergency stop switch.

The buzzer stops sounding.

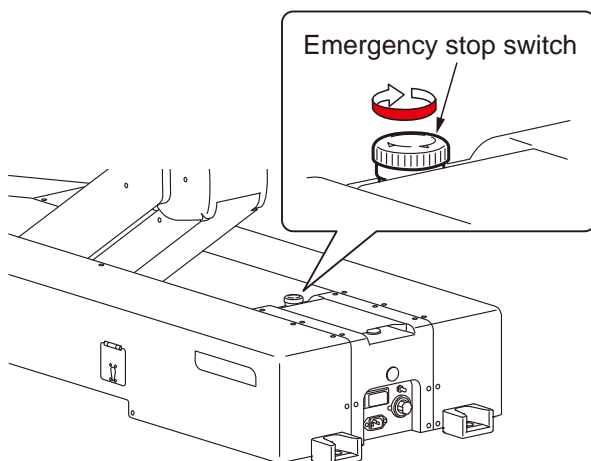

CAUTION

To reset the operating table to the original position in an emergency where, for example, an operator's hand is caught in a gap of the operating table, press the switch on the control unit to move the table toward the reverse direction.

6.3 Fixing and unfixing the operating table

■ Fixing the operating table

Before you operate the operating table, activate the brake to fix the operating table.

1. Press **E** first and then .

The brake is activated to lock the operating table, the brake lamp on the base turns blue, and  appears on the monitor screen.

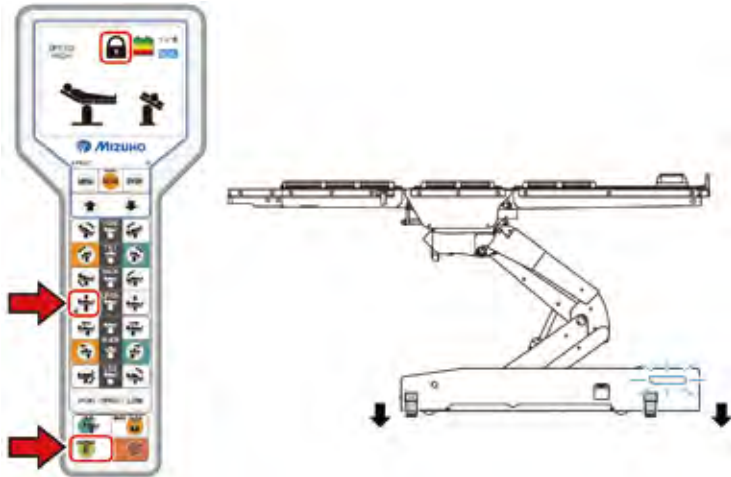

After activating the brake, check that the operating table is fixed securely.

NOTE

- If the brake cannot be activated and the operating table is not fixed, refer to "Troubleshooting".
- Operations such as raising the tabletop will not operate until the fixing of the tabletop is completed.
- When this product is used with the battery, the brake lamp on the base turns off after 3 minutes.
- The function does not work even if you pressed the function switch before pressing **E**.

■ Unfixing the operating table

To move the operating table, unfix the operating table.



Do not unfix the operating table with a patient on it.
The patient may fall from the operating table.

1. Press **E** first and then .

The brake is released for unfixing the operating table, and the brake lamp on the base turns orange, and  appears on the monitor screen.

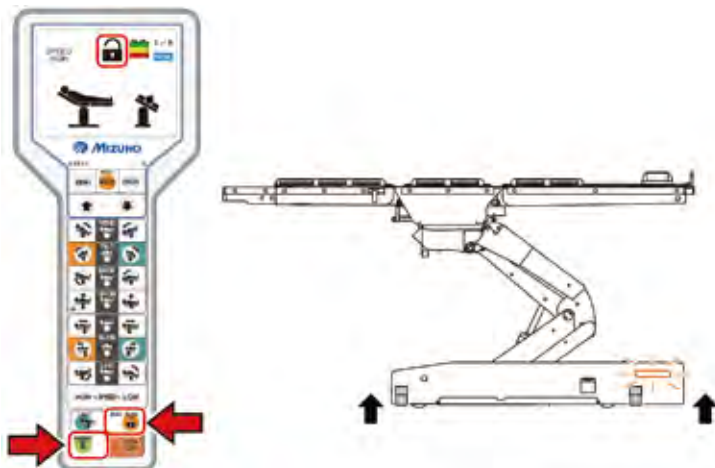

NOTE

It takes about 15 seconds until the operating table is unfixing.

6.4 Tilting the tabletop laterally



WARNING

When you tilt the tabletop laterally, make sure to use the fixture for the accessory of the Mizuho operating table. The patient may fall from the operating table.

■ Tilting to the left

1. Press **E** first and then .

The tabletop tilts to the left in the view from the head side.

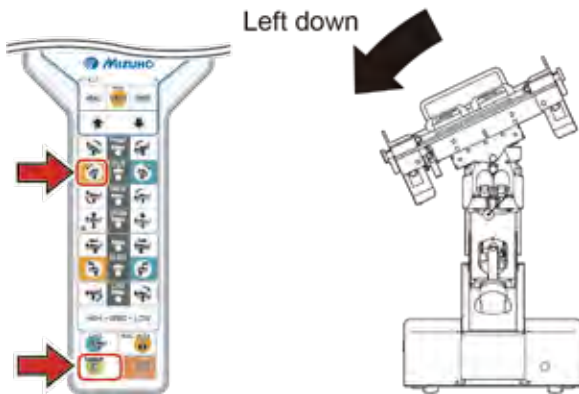

NOTE

- The angle achieved in the right down and left down position is up to 25° to the level position.

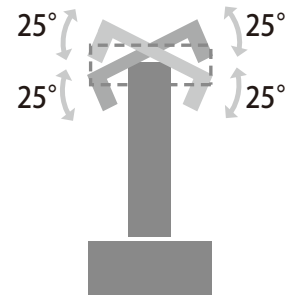

- If the tabletop is tilted laterally to its maximum extent, the right-left sliding position may move a little.

■ Tilting to the right

1. Press **E** first and then .

The tabletop tilts to the right in the view from the head side.

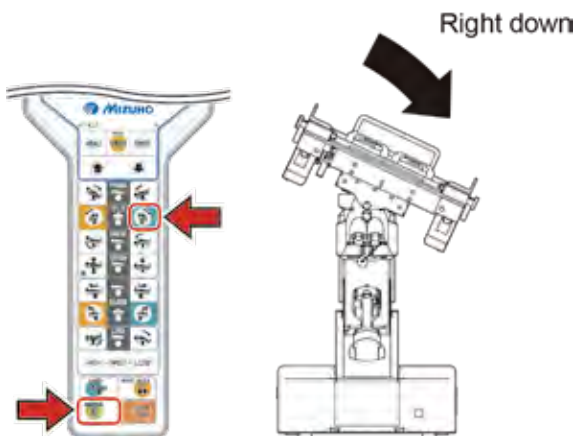

6.5 Trendelenburg



When you operate the Trendelenburg operation, make sure to use the fixture for the accessory of the Mizuho operating table. The patient may fall from the operating table.



When performing the head down operation, be careful that the head plate tip does not contact the floor. It may get damaged.

■ Reverse Trendelenburg (Head up)

1. Press **E** first and then .

The tabletop moves to the head up position.

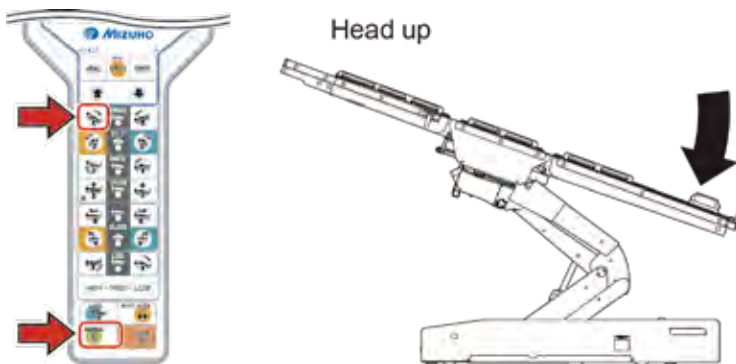

NOTE

The angle of head up is up to 20° to the level position.

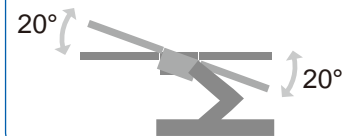

■ Trendelenburg (Head down)



When the operating table is put into the Trendelenburg with any accessory such as a head frame attached, do not operate the table until the accessory contacts with the floor. It may get damaged.

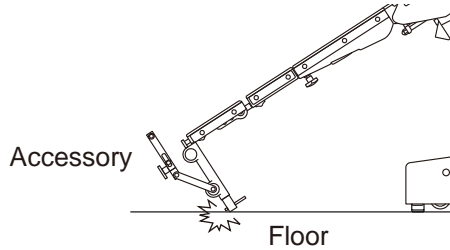

NOTE

The angle of head down is up to 45° to the level position.

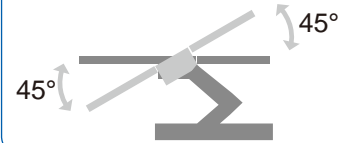

1. Press **E** first and then

The tabletop moves to the head down position.

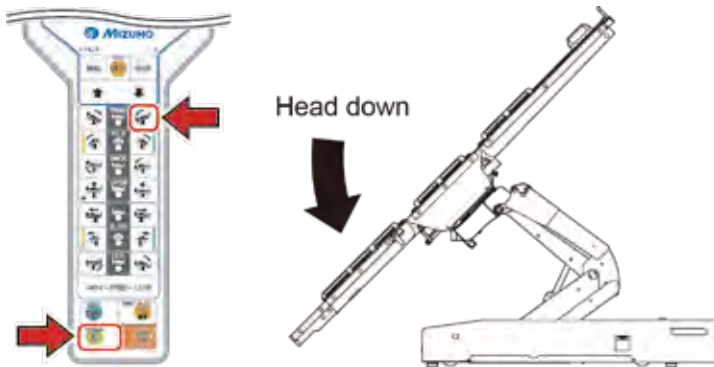

6.6 Tilting the back plate



WARNING

Keep your hands away from the following gap during the operation of the table. You may get injured.

- Gap between the back plate and waist plate

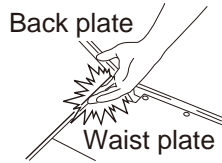

■ Moving up the back plate

1. Press **E** first and then .

The back plate moves up.

NOTE

The angle achieved in the back plate up position is up to 90° to the level position.

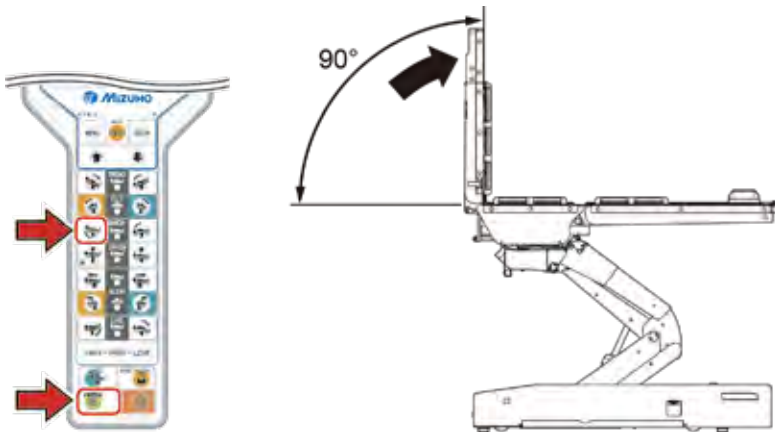

■ Moving down the back plate



When the back plate is moved down with any accessory such as a head frame attached, do not operate the table until the accessory contacts with the floor. It may get damaged.

NOTE

The angle achieved in the back plate down position is up to 30° to the level position.

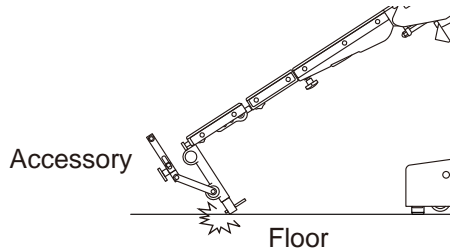

1. Press **E** first and then .

The back plate moves down.

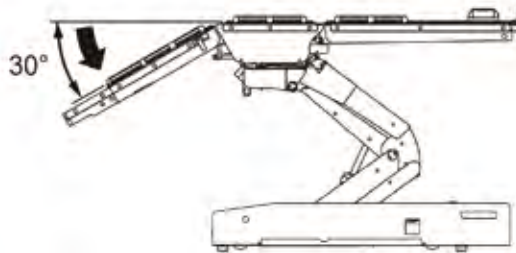

6.7 Tilting the leg plate



WARNING

Keep your hands away from the following gap during the operation of the table. You may get injured.

- Gap between the leg plate and waist plate
- Gaps between the leg plate links

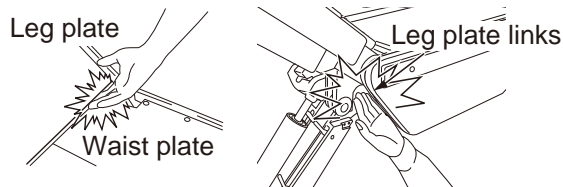

CAUTION

When performing the leg down operation, be careful that the leg plate tip does not contact the floor or the base. It may get damaged.

6

Operation

■ Moving up the leg plate

1. Press **E** first and then .

The leg plate moves up.

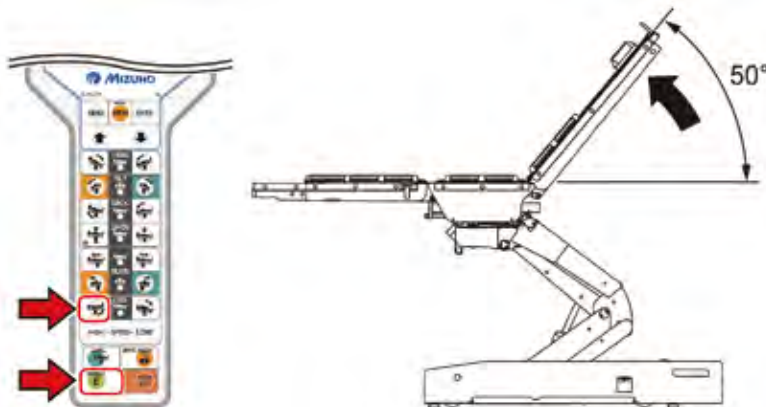

NOTE

- The angle achieved in the leg plate up position is up to 50° to the level position.
- The angle achieved in the leg plate down position is up to 45° to the level position.

■ Moving down the leg plate

1. Press **E** first and then .

The leg plate moves down.

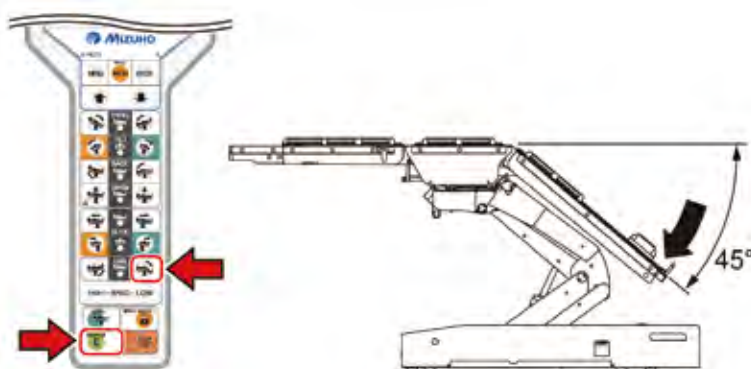

6.8 Changing the tabletop height



Keep your hands away from the shaded area shown in the figure below during the operation of the table. You may get injured.

Also, do not put any object in the shaded area. Otherwise, the sensor detects the object and halts the lowering operation which may get damaged.

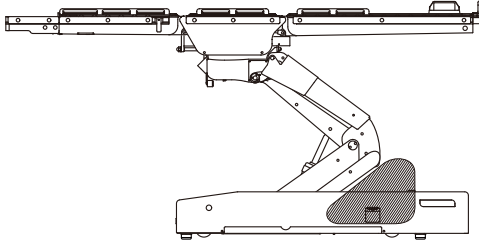

■ Moving up the tabletop

1. Press **E** first and then .

The tabletop moves up.

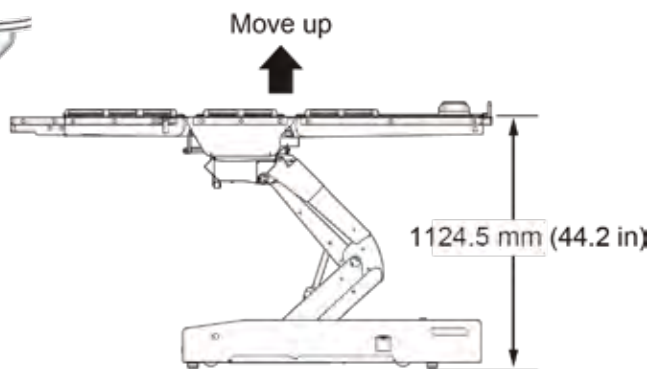
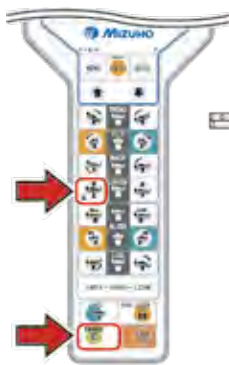

NOTE

The height from the floor to the tabletop upper surface is up to 1124.5mm (44.2 in).

■ Moving down the tabletop



When the tabletop is moved down with any accessory such as a head frame attached, do not operate the table until the accessory contacts with the floor. It may get damaged.

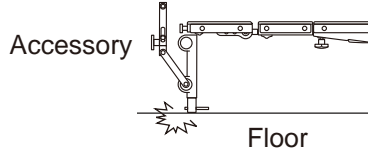

NOTE

The height from the floor to the tabletop upper surface is down to 474.5mm (18.6 in).

1. Press **E** first and then .

The tabletop moves down.

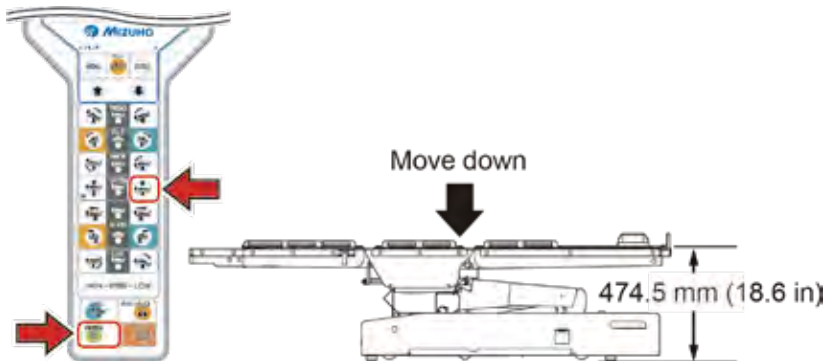

6.9 Sliding the tabletop

■ Sliding in the foot direction

1. Press **E** first and then .

The tabletop slides in the foot direction.

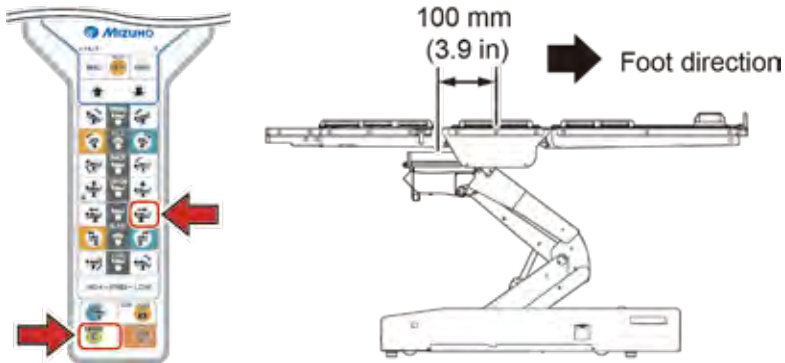

NOTE

- Maximum travel in sliding from the center position of the tabletop is as follows.
 - Foot direction: 100 mm (3.9 in)
 - Head direction: 100 mm (3.9 in)
- The tabletop does not move toward the foot direction at the head down position over 15 degrees.

■ Sliding in the head direction

1. Press **E** first and then .

The tabletop slides in the head direction.

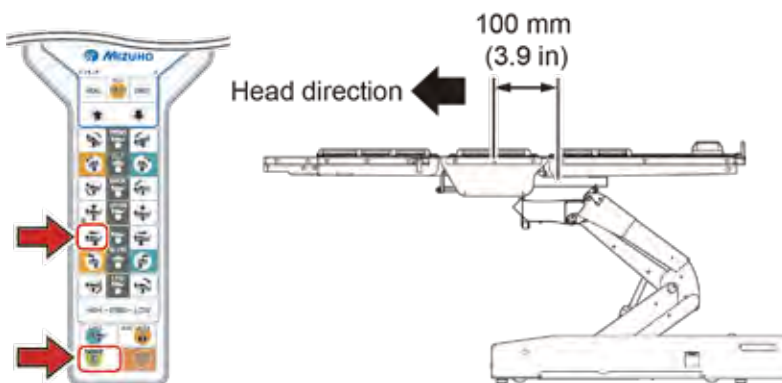

■ Sliding in the left direction

1. Press **E** first and then .

The tabletop slides in the left direction.

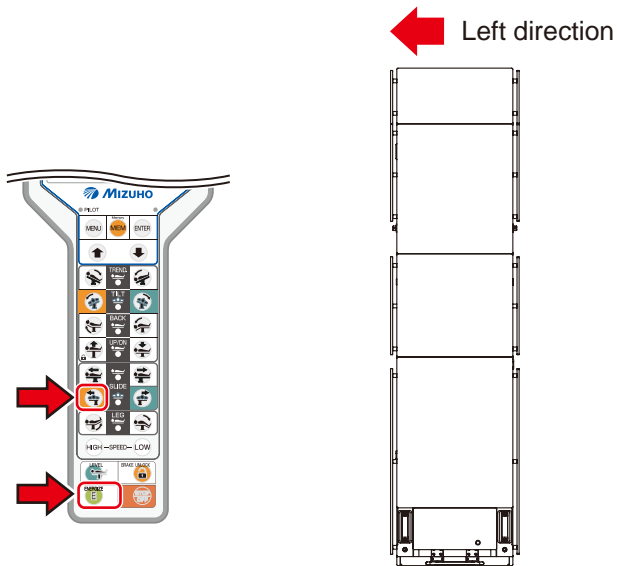

NOTE

Maximum travel in sliding from the center position of the tabletop is as follows.

- Right direction: 80 mm (3.1 in)
- Left direction: 80 mm (3.1 in)

■ Sliding in the right direction

1. Press **E** first and then .

The tabletop slides in the right direction.

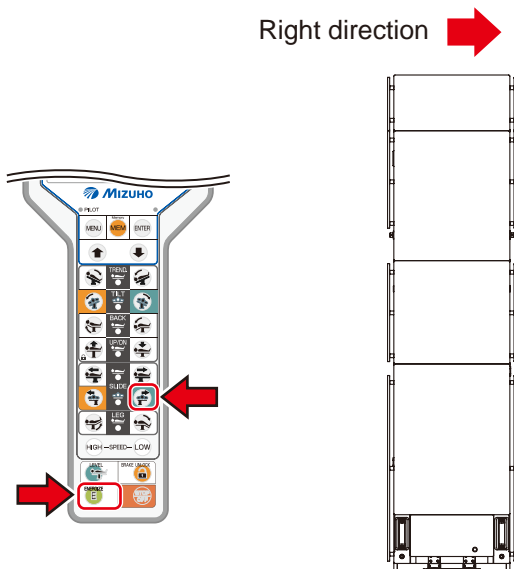

6.10 Operating memory

You can memorize any table top position and easily reproduce a desired one from among the memorized positions.

■ Registering a position of the tabletop

1. Put the tabletop to a position you wish to register.
2. Press **MENU** several times until a memory in which you wish to register appears.

NOTE

- The number of operations to be registered is up to 3.
- If you over write a position onto a memory that has been registered with any position, the operation is deleted.

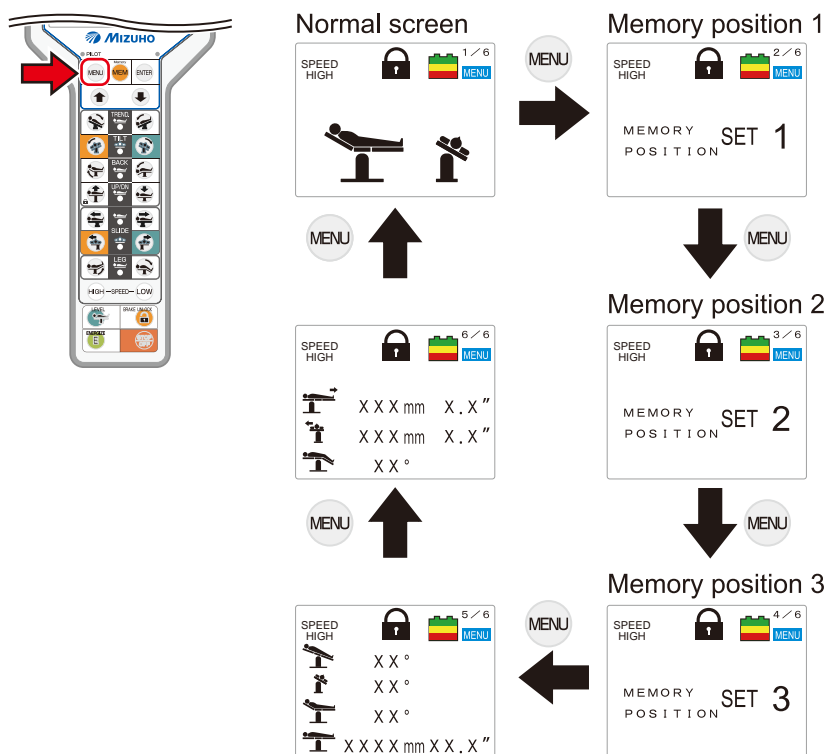

3. Press **ENTER**.

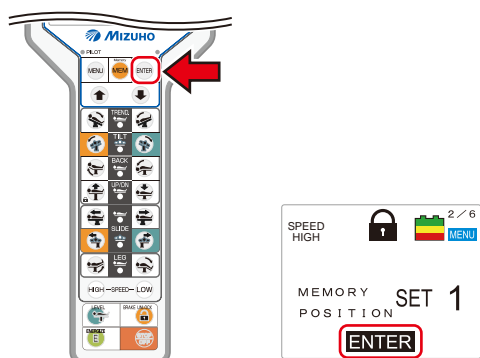

The position is registered in the memory and display "ENTER" on the monitor.

4. Press **MENU** several times until the normal screen appears.

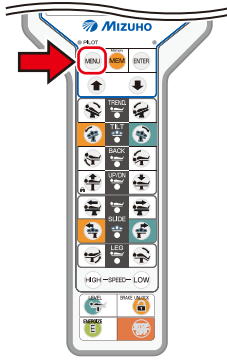

■ Reproducing a registered position

1. Press **MEM** several times until a memory in which you wish to register appears.

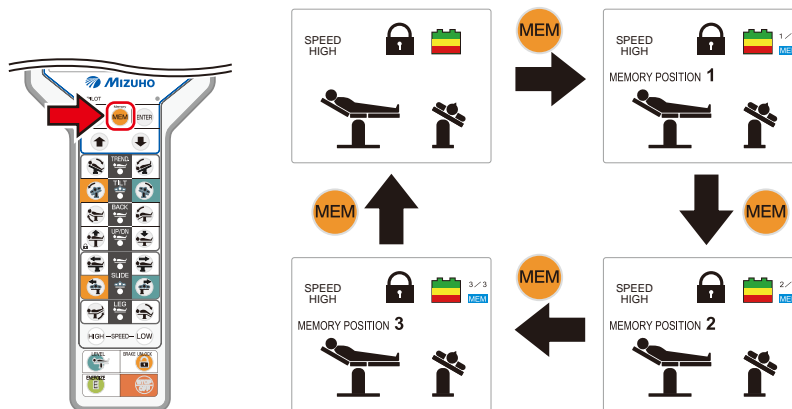

2. Press **E**.

A function button necessary for reproducing the position lights up.

3. Keep pressing the button lit until the tabletop stops moving.

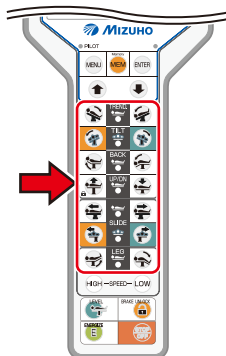

The function button you operated lights off.

4. Repeat step 3 until all the function buttons lit off.

When the tabletop is moved to the target position, the number of "MEMORY POSITION" turns blue.

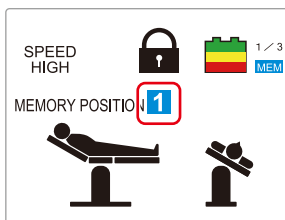

NOTE

In the ISO CENTER mode, always operate the lateral tilt first before the slide right or left when you operate these two operations by the memory function. Otherwise, a travel of the operating table may increase.

6.11 Checking the current position of the tabletop

You can check the current position of the table top in a specific number.

1. Press **MENU** several times until the 5/6 screen appears.

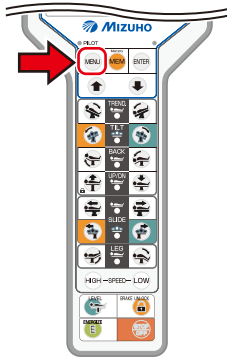

2. Check the travel of "Trendelenburg", "Lateral tilt", "Back plate bending", or "Lift".

SPEED HIGH	Lock Icon	5 / 6	MENU	
	X X °	_____		Trendelenburg
	X X °	_____		Lateral tilt
	X X °	_____		Back plate bending
	X X X X mm	X X . X "		Lift

3. Press **MENU** to go to the 6/6 screen, and check the travel of "Head to leg slide", "Left to right slide", or "Leg plate bending".

SPEED HIGH	Lock Icon	6 / 6	MENU	
	X X X mm	X . X "		Head to leg slide
	X X X mm	X . X "		Left to right slide
	X X °	_____		Leg plate bending

4. Press **MENU**.

The normal screen (1/6 screen) appears.

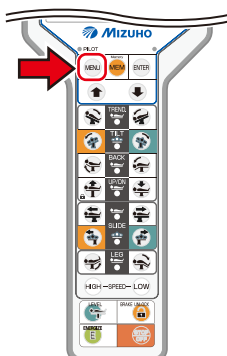

6.12 Returning to level

■ Returning the tabletop to level position

1. Press **E** first and then .

The operating table moves following the steps below and the table top returns to the level position.

1. Trendelenburg, lateral tilting, back plate tilting, and leg plate tilting
2. Right-to-left slide
3. Head-to-leg slide

NOTE

The lifting, fixing, and braking functions do not work.



Be sure to check visibly that the table top returned to the level position.

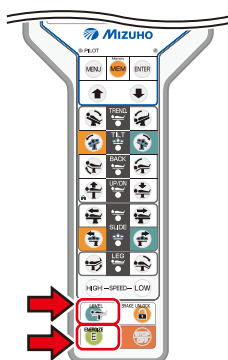

● If the tabletop is not level

If the tabletop is not level after pressing the "Level" button, press the left or right "Lateral tilt" button to tilt the table beyond level.

This will cause the table's positioning software to recognize a new position.

After tilting the table beyond level, depress the "Level" button again.

The table will return to level. If the table does not return to level, please contact your distributor or Mizuho for service.

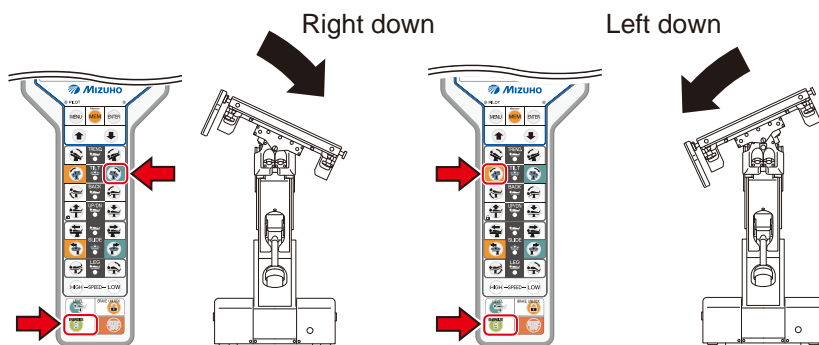

6.13 Connecting with the trolley

■ Moving the trolley

To connect this product with the trolley, move the trolley.

For how to move the trolley, refer to the "Trolley operator's manual".

■ Preparing this product for connection with the trolley

Follow the steps below to make this product ready for connection with the trolley.

1. Detach the head plate from the operating table.
2. Press **E** first and then .

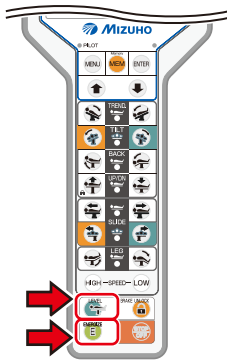

The tabletop returns to the level position.

3. Be sure to check visibly that the table top returned to the level position.
4. Press **E** first and then  to raise the tabletop more than the trolley.

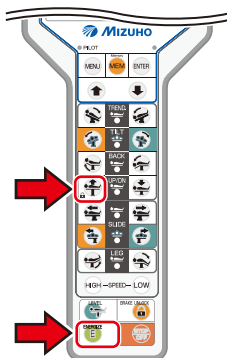

5. Press **E** first and then  to lower the tabletop until the tabletop stops.

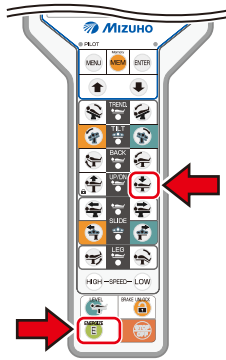

6. Be sure to check visually that the tabletop and the trolley are on the same level.

■ Connecting/disconnecting the trolley and this product

For how to connect and disconnect the trolley and this product, refer to the "Trolley operator's manual".

6.14 Sliding the transfer board

For details of how to slide the transfer board, refer to the "Trolley operator's manual".

This section describes locking and unlocking of the transfer board when sliding the transfer board.



WARNING

Do not put your fingers or cloth into any gaps when sliding the transfer board. The gaps may get your fingers or cloth caught in.



CAUTION

- Do not slide the transfer board when the trolley is not connected. Otherwise, the transfer board may get damaged.
- Before locking/unlocking the transfer board, level the tabletop using the control unit. For the operation, refer to Page 54 .

■ Unlocking the transfer board

To unlock the transfer board, follow the procedure below.

1. Turn the transfer board release levers (for the back plate), which are attached to both sides of the back plate, in the direction of arrow to release the back plate lock.

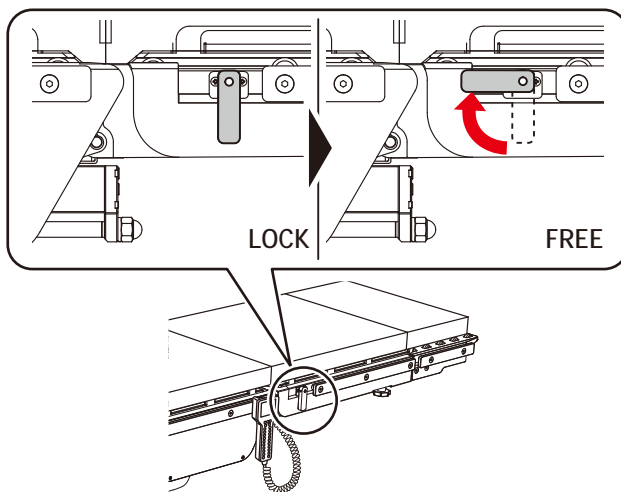

2. Detach the key lock attached to the transfer board to unlock.

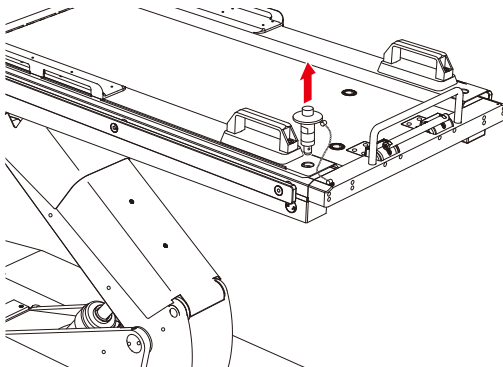

3. Lower the transfer board release lever (for the leg plate), which is attached to the tip of the leg plate, in the direction of arrow to release the leg plate lock.

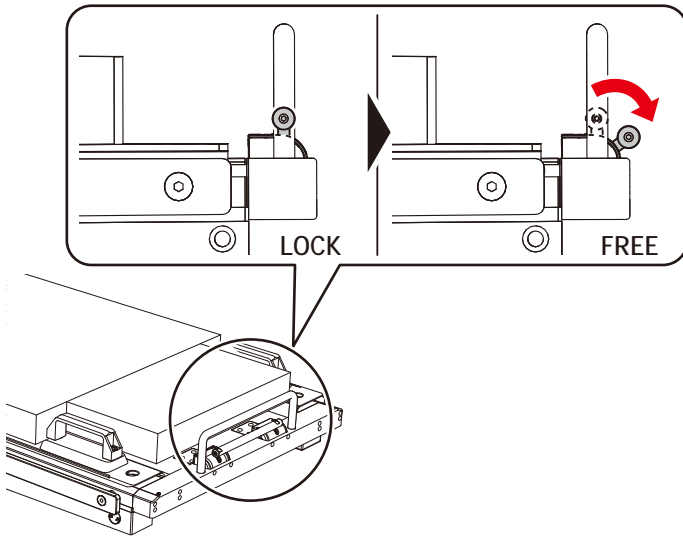

■ Locking the transfer board



Before operation, check that the right and left levers are at locking positions.

NOTE

To locking the transfer board, reversely follows the unlocking procedure.

1. Check that the leg plate is locked by the transfer board release lever (for the leg plate) attached to the tip of the leg plate.
2. Attach the key lock to the transfer board to lock.
3. Turn the transfer board release levers (for the back plate), which are attached to both sides of the back plate, in the direction of arrow to lock the back plate.

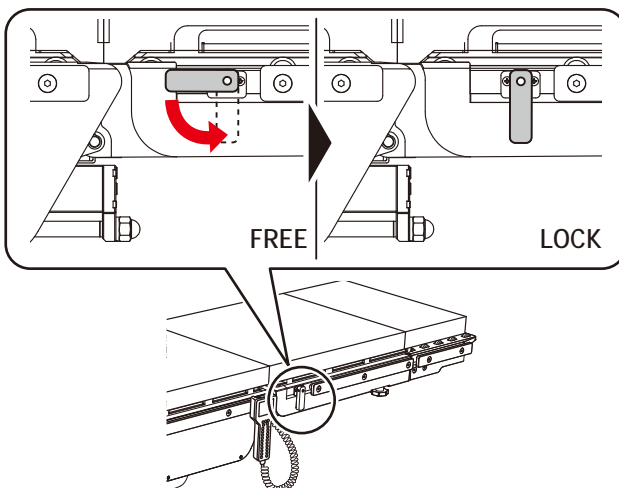

■ Moving the transfer board to the trolley

1. Check that this product is connected with the trolley.

For how to connect this product and the trolley, refer to the "Trolley operator's manual".



CAUTION

After checking that this product is connected with the trolley, move the transfer board.

Otherwise, the transfer board may get damaged.

2. Unlock and move the transfer board to the trolley.

■ Returning the transfer board from the trolley

1. Check that this product is connected with the trolley.

For how to connect this product and the trolley, refer to the "Trolley operator's manual".



CAUTION

After checking that this product is connected with the trolley, move the transfer board.

Otherwise, the transfer board may get damaged.

2. Unlock and move the transfer board to this product.

6.15 Attaching/detaching head plate

The head plate is detachable.

■ Detaching the head plate



The head plate weighs 7 kg (15 lbs). Pay special attention when handling it. It may drop and cause damage or injury.

1. Loosen the two head plate fixing knobs located on the lower side of the back plate.
2. Hold the both sides of the head plate firmly and pull it straight.

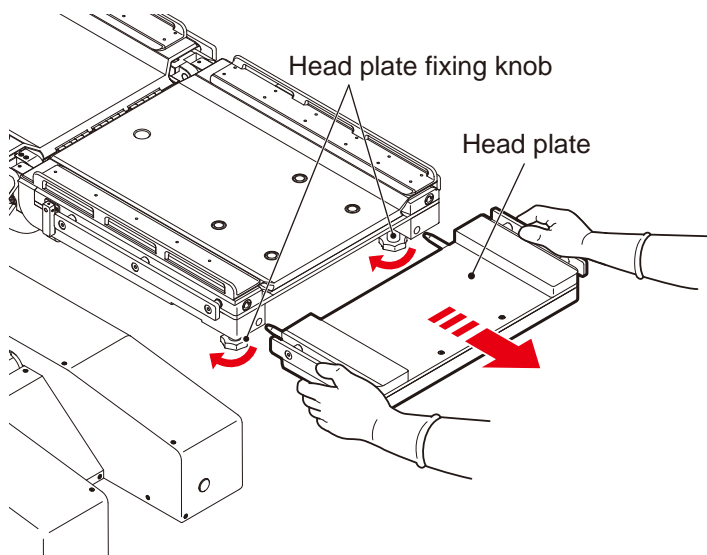

■ Attaching the head plate



WARNING

- Make sure to tighten the head plate fixing knobs securely.
If the head plate moves, the patient may get injured.
- The head plate weighs 7 kg (15 lbs). Pay special attention when handling it. It may drop and cause damage or injury.

1. Hold the both sides of the head plate firmly and align the insertion shaft of the head plate with the reception hole in the back plate, and insert.
2. After checking that the head plate is completely inserted, tighten the two head plate fixing knobs located on the lower side of the back plate.

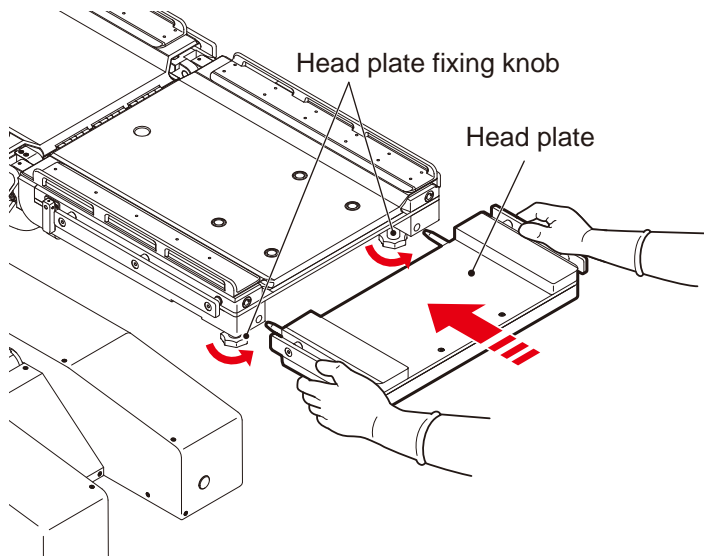

CAUTION

Insert the head plate entirely into the back plate. Use of the head plate inserted incompletely may cause damages.

6.16 A-line pole

This pole supports a tube for A-line.



This is a pole for supporting, for example, an A-line pole tube. Do not hold the pole to push the transfer board.

■ Attaching the A-line pole

1. Remove the leg plate auxiliary mattress.
2. Fix the A-line pole to the transfer board.

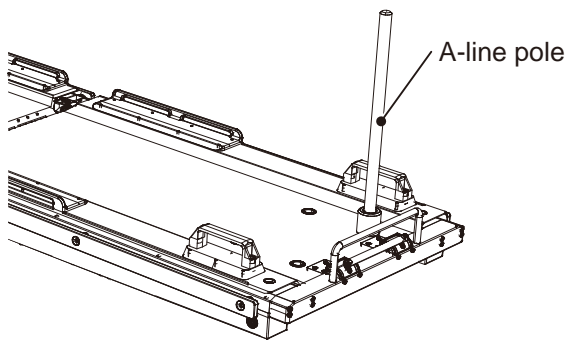

7. Maintenance and inspection

7.1 Inspection before and after use



WARNING

- Make sure to inspect the items below before and after use. If there are any abnormalities, request your distributor or Mizuho for repairs. Otherwise it may cause problems during surgery.
- In a MRI room, do not perform maintenance work. Electromagnetic from MRI may cause troubles to operators and/or other devices.

Inspect the items below. If there is any problem, request your distributor or Mizuho for repair.

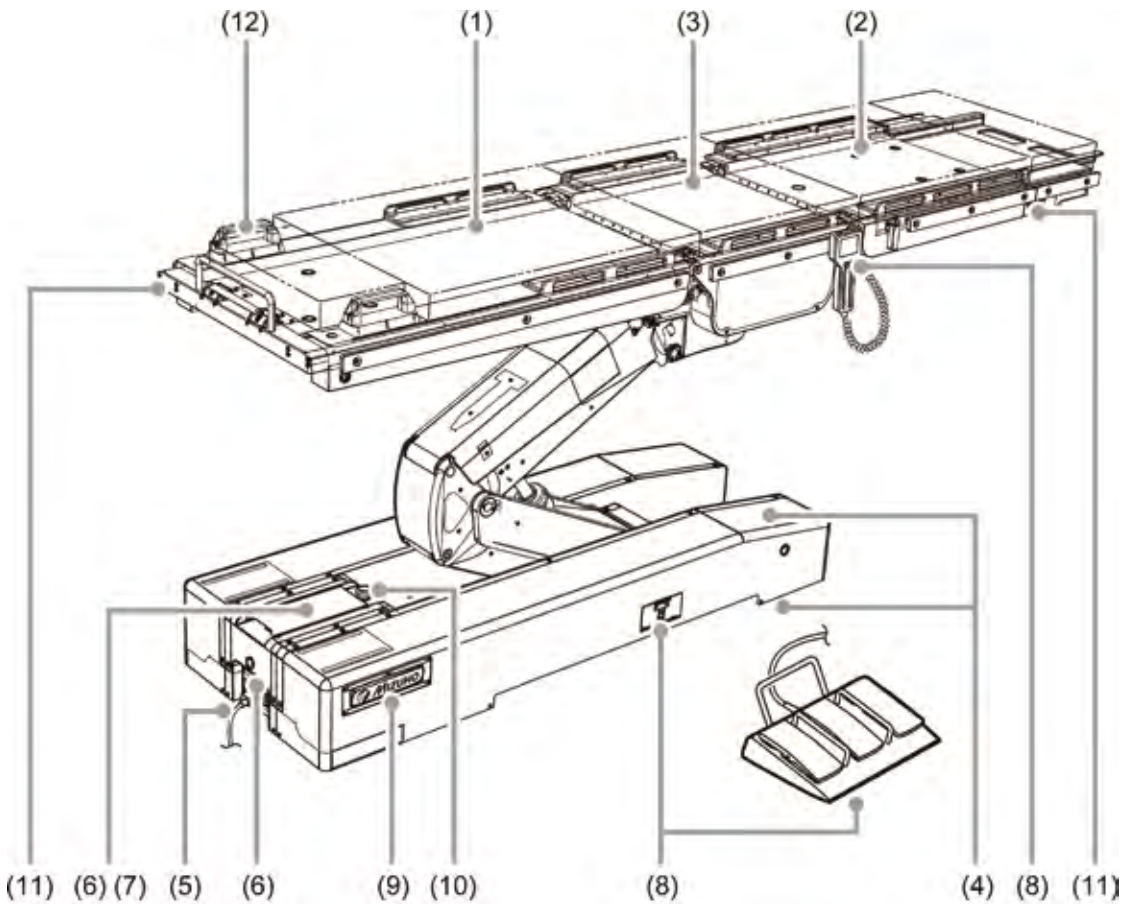

(1) Mattresses

● Before use

Check all the mattresses for any damage.

● After use

Check all the mattresses for any damage or dirt.

(2) Backlash of the tabletop

● Before use

Check all the table plates for any backlash when jiggling both ends of the back plate.

(3) Table plates

● Before use

Check all the table plates for any damage.

● After use

Check all the table plates for any damage or dirt.

(4) Oil leakage

● Before and after use

Check the floor or the base surface for any hydraulic oil.

(5) Power cord and plug

● Before use

Check the power cord for any exposed wire and the plug for any damage.

(6) Power switch

● Before use

Turn on the power switch to check if the LED lamp of the power switch and the touch panel turn on.

(7) Battery level

● Before use

Check if the battery has been charged.

(8) Control unit, foot switch (optional), extra switch

● Before use

- Press the switches of control unit, foot switch (optional), and extra switch to check if all functions work properly.
- Check if all indicators turn on.

(9) Brake lamp

● Before use

- Check if the brake lamp lights up when the power is turned on.
- Check if the brake lamp changes color when the brake status is changed.

(10) Emergency stop switch

● Before use

Check if the emergency switch works properly.

(11) Connection of the operating table, the trolley and the MRI device

● Before use

Check if the operating table, the trolley and the MRI device can be connected properly.

(12) Transfer board

● Before use

Check if the transfer board can be moved between the operating table, the trolley and the MRI device properly.

7.2 Periodic replacement parts

Mizuho specifies that the following parts need to be periodically replaced for safety use.

The replacement time is a rough standard. Earlier replacement may be required depending on the usage condition and/or usage frequency.

Request your distributor or Mizuho for replacements.

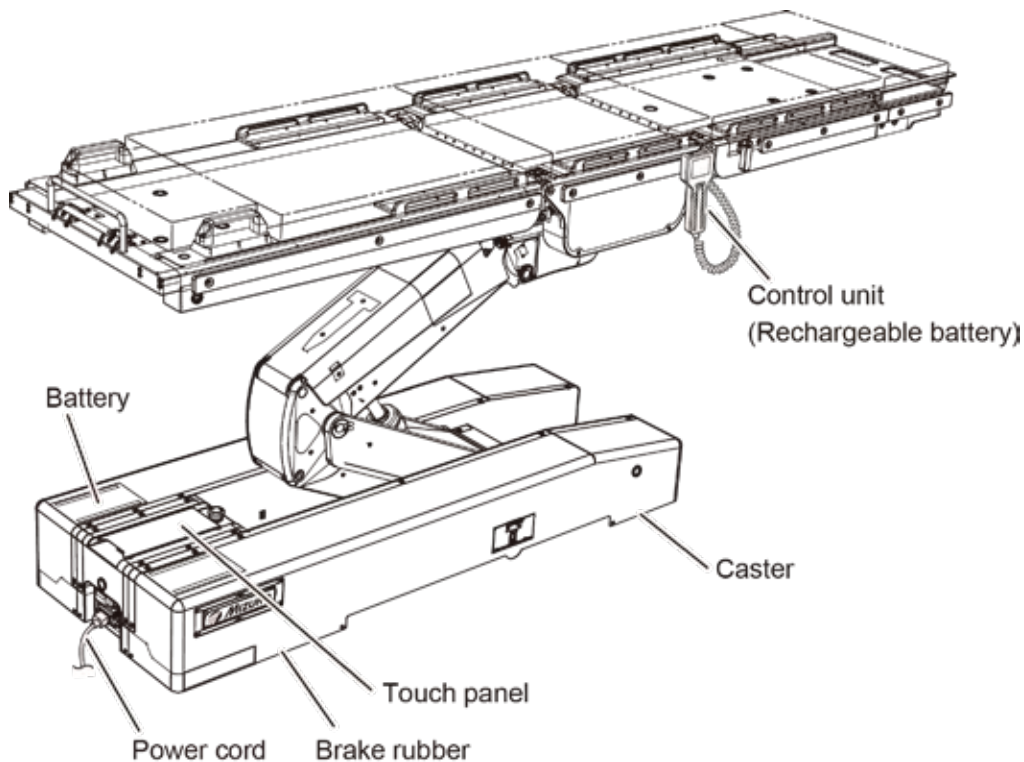

Parts	Replacement time (years)
Battery	2
Control unit	4 to 6
Control unit (rechargeable battery)	2 to 3
Caster	5 to 7
Brake rubber	3 to 5
Power cord	5 to 7
Touch panel	5 to 7

NOTE

The aforementioned are estimated times. The replacement time may depend on usage condition and/or usage frequencies.

7.3 Version information of the software

The version information for the control software which is installed in the operating table can be verified via the label that is directly applied on the on-board microcomputer.



The version information of the software is mainly for the service and maintenance personnel as needed. For confirmation, open the leg plate cover to access the control board.

8. Specification

8.1 Specification table

Product name		MST-7300BX-MR·T Intraoperative diagnosis operating table system	
Electromotive functions	Elevation range	Highest	1124.5 mm ± 10 mm (44.2 in)
		Lowest	474.5 mm ± 10 mm (18.6 in)
	Trendelenburg angle	Head up	20° ± 2°
		Head down	45° - 2° / + 10°
	Lateral tilt angle	Right down	25° ± 2°
		Left down	25° ± 2°
	Back plate flexing angle	Up	90° ± 2°
		Down	30° ± 2°
	Leg plate flexing angle	Up	50° ± 2°
		Down	45° ± 2°
	Sliding: Note 1	Head direction	100 mm ± 10 mm (3.9 in)
		Foot direction	100 mm ± 10 mm (3.9 in)
		Left direction	80 mm ± 10 mm (3.1 in)
		Right direction	80 mm ± 10 mm (3.1 in)
	Returning to level		Trendelenburg / Lateral tilt / Back plate bending / Leg plate bending / Slide
Brake		Lock / unlock	
Control devices	Control unit: Note 2	Memory, Trendelenburg, Lateral tilt, Back plate bending, Leg plate bending, Lift, Sliding, Switching speed, Returning to level, Brake, E switch, Power Off	
	Touch panel: Note 2	Memory, Trendelenburg, Lateral tilt, Back plate bending, Leg plate bending, Lift, Sliding, Switching speed, Returning to level, Brake, ISO CENTER mode, Level position pause mode	
	Extra switch	Trendelenburg, Lateral tilt, Back plate bending, Leg plate bending, Lift, Sliding, Brake	
	Foot switch: Note 3	Trendelenburg, Lateral tilt, Lift	
	Emergency stop switch	Stop	
Manual functions	Detachment		Head plate / Transfer board
	Others		Locking/unlocking of the transfer board: Note 4
			Movement of the transfer board: Note 5
			Connection with and disconnection from the trolley
		Emergency brake release dial	

Rating	Classification as per	Class I device (internal power source device : Note 6)
	Rated voltage	AC 100 - 240 V
	Frequency	50-60 Hz
	Battery power	DC 24 V
	Power input	700 VA
	Operating voltage	24 V
	Duty cycle	3 min on, 7 min off : Note 7
	Others	Recovery from defibrillator is within five seconds. Conformity to EMC Standard IEC 60601-1-2
Applied part	B type applied part	Head plate / Transfer board (Back plate / Waist plate / Leg plate)
	Defibrillation-proof applied part	Mattresses (Head plate / Back plate / Waist plate / Leg plate / Auxiliary leg plate)
Water resistant class		IPX4
Dimension	Tabletop	2147mm (84.5 in) (L) x 500 mm (19.6 in) (W) : Note 8
	Base	1335 mm (52.5 in) (L) x 500 mm (19.6 in) (W) : Note 9
Weight		380 kg (837 lbs)
Allowable load		250 kg (551 lbs)
Transitable height and width		Height : 10 mm / Width : 80 mm
Operating environment	Temperature	10 to 40°C : Note 12
	Humidity	30 to 75% : Note 12
	Atmospheric pressure	700 to 1060 hPa : Note 12
	Others	Allowable altitude for use is 3000 m or lower.: Note 12
Transportation and storage	Temperature	-10 to 50°C : Note 10
	Humidity	10 to 85% (without moisture condensation) : Note 10
	Atmospheric pressure	700 to 1060 hPa : Note 10
Service life		Under the specified maintenance and proper storage, 10 years : Note 11

Note 1: from the center position

Note 2: The control software version is labeled on the device inside the base.

Note 3: Optional

Note 4: Release lever (back plate / leg plate), key lock (leg plate)

Note 5: The transfer board is moved in a state of connection with the trolley

Note 6: When the battery power is used

Note 7: Consecutive pressing of the switch of the control unit.

Note 8: Excluding the side rail

Note 9: Rough dimension

Note 10: Company standard (in case that appropriate maintenance and inspection is done)

Note 11: Based on Mizuho's own validation data

Note 12: IEC 60601-1, Medical electrical equipment - Part1: General requirements for safety

8.2 External view

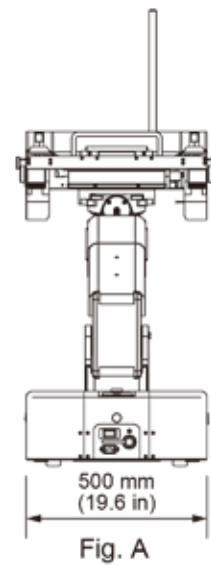
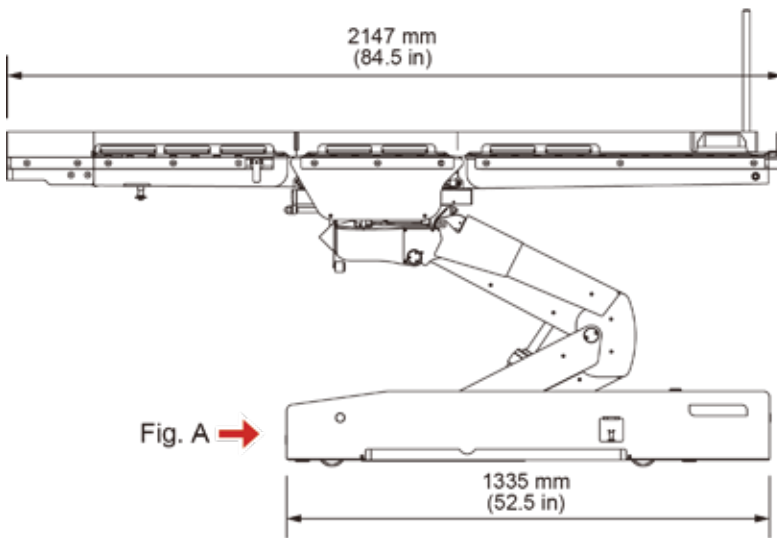
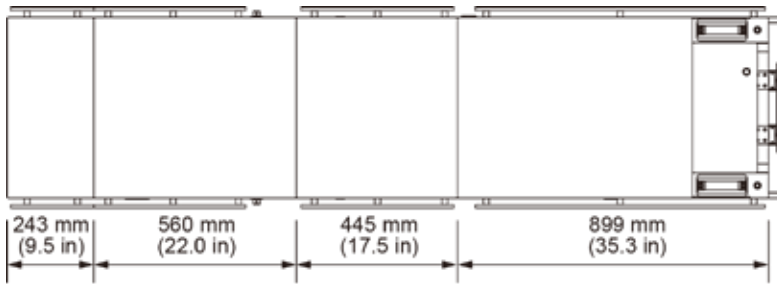

9. Troubleshooting

■ When the control unit cannot be used

The extra switch should be used only in an emergency.



- Unlike the control unit, the extra switch has no function to halt the operation of the buttons.
- Always watch movement of the operating table when you operate the extra switch.
- If any parts come in contact with each other, immediately stop the operation. Otherwise, the operating table may get damaged.

NOTE

- The operating table always moves in the high speed mode when being operated by the extra switch.
- When the extra switch is used for the operation, the ISO CENTER mode does not function.

● Use the extra switch to operate the operating table

1. Open the latch of the extra switch.
2. Open the lid of the extra switch.

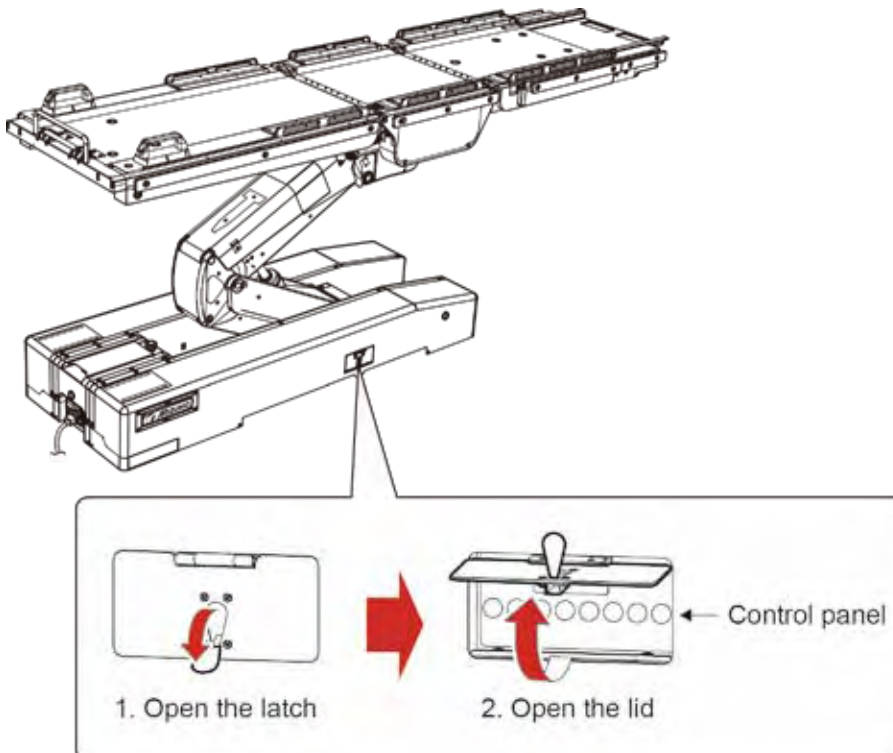

3. Press any function button on the control panel according to the desired direction.

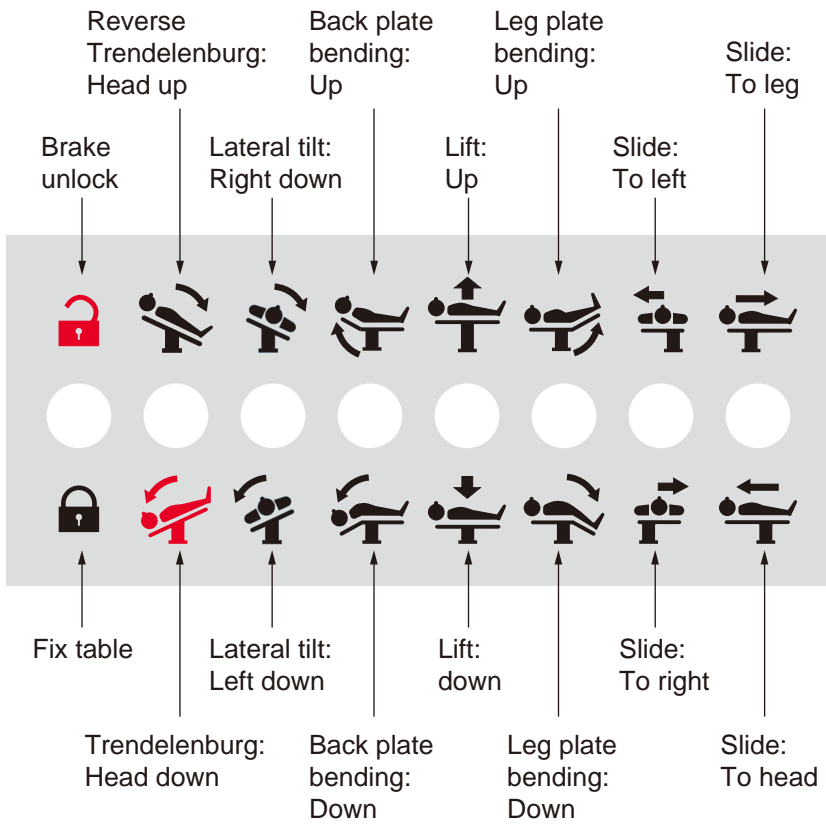

NOTE

The operating table moves while the switch is being pressed. The table stops once the maximum angle is achieved.

● Use the emergency brake release dial to release the brake



Do not tilt the tabletop while the emergency brake release dial is in the "UNLOCK" position.
The patient may fall from the operating table.

In case of electrical trouble, the operating table can be moved by using the emergency brake release dial.

Follow the procedure below to release the brake.

1. Open the latch of the emergency brake release dial.
2. Open the lid of the emergency brake release dial.

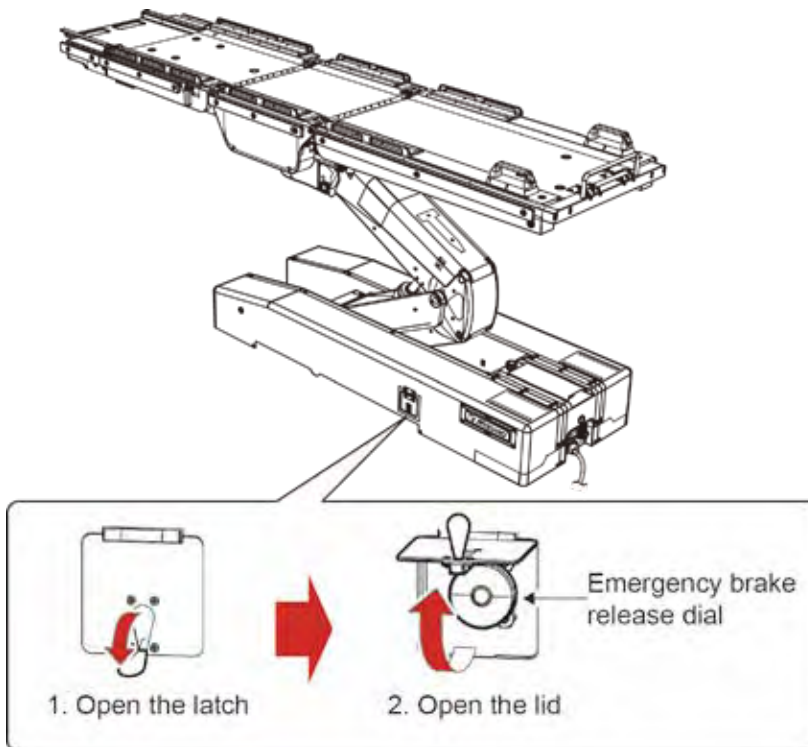

3. Turn the emergency release dial clockwise (to the right).

The brake is released.

Turn the dial

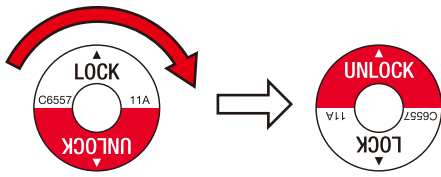

To move the operating table after you released the brake, activate the brake again with the following procedure. If the operating table is moved with the brake released, the patient may fall from the operating table.

1. Turn the emergency release dial counterclockwise (to the left).

Turn the dial



2. Press **E** first and then  on the control unit.

The operating table is fixed.

■ In case where any caution/warning appeared

If any caution/warning message appeared on the touch panel and the display monitor, follow the description below to take an appropriate action.

● Caution/warning for other than the touch panel

Display		Measures
Touch panel	Monitor	
Valve Thermal The valve's thermal switch for locking is on. Wait 30 minutes before use.	No.01	Wait 30 minutes, and then use again.
Table Section Collision The head plate is about to contact the floor.	No.02	To continue the current operation, perform the operations below to lift the head plate. <ul style="list-style-type: none"> • Reverse Trendelenburg (→ Page 40) • Back plate bending: Up (→ Page 42) • Lift Up (→ Page 45)
Table Section Collision The waist plate is about to contact the operating table.	No.03	To continue the current operation, perform the operations below to lift the waste plate. <ul style="list-style-type: none"> • Lateral tilt in the return direction (→ Page 39) • Trendelenburg in the return direction (→ Page 40) • Lift Up (→ Page 45)
Table Section Collision The leg plate is about to contact the operating table.	No.04	To continue the current operation, perform the operations below to lift the leg plate. <ul style="list-style-type: none"> • Leg plate bending: Up (→ Page 44) • Trendelenburg (→ Page 40) • Lift Up (→ Page 45)
Motor Lock The motor is locked and supplied with overcurrent. Request repairs from Mizuho or your distributor.	No.05	Request repairs from your distributor or Mizuho.
Power Supply The AC power has broken down. Request repairs from Mizuho or your distributor.	No.06	Request repairs from your distributor or Mizuho.
Fuse The fuse has blown out. It can't be used by a battery mode. Request repairs from Mizuho or your distributor.	No.07	Request repairs from your distributor or Mizuho.
Emergency Switch The emergency stop switch was pressed. Check the safety and then deactivate the switch.	No.08	Check the safety and then deactivated the emergency stop switch.
Battery Discharged The battery is out of charge. Charge the battery.	No.09	Charge the battery.
Brake Lock The surgical table cannot be locked. Check if the emergency brake is released.	No.10	Lock the emergency brake again.

Display		Measures
Touch panel	Monitor	
Pendant Control Communication The control cannot be communicated with. Use the control unit wirelessly or extra controls or the touch panel.	No.11	Use the control unit wirelessly, the extra switch, or the touch panel.
Rotary Encoder Communication The Rotary encoder cannot be communicated with. Request repairs from Mizuho or your distributor.	No.12	Request repairs from your distributor or Mizuho.
Rx Microcomputer Communication The Rx microcomputer cannot be communicated with. Request repairs from Mizuho or your distributor.	No.13	Request repairs from your distributor or Mizuho.
Table Down Sensor The sensor at the lift linkage is on. Check if any object is caught in the linkage.	No.14	Remove the object. (→ Page 45)
Trend,Table-Down Switch "Reverse trend." and "Table-down" are disabled due to their contact prevention switch working.	No.15	To continue the current operation, perform the operations below. • Trendelenburg (→ Page 40) • Lift Up (→ Page 45)
Pump Thermal The thermal switch of the pump motor is on. Wait 30 minutes before use.	No.16	Wait 30 minutes and then operate the operating table again.
5V Power The 5V power of the main board is off. Request repairs from Mizuho or your distributor.	No.17	Request repairs from your distributor or Mizuho.
Remote Control Code The code no. of the remote controller is incorrect. Correct the code no. in the maintenance mode.	No.18	Request repairs from your distributor or Mizuho.
Head Is Below The Heart The head may go below the heart. Carefully adjust the position.	No.19	Check the patient's condition.
Table Section Collision The sliding rail is about to contact the lift cover.	No.20	Execute the Trendelenburg of the operating table to the level position or the reverse Trendelenburg position. (→ Page 40)
"E" Button No "E" is entered from the control unit or the foot switch. Use the extra controls or the touch panel.	No.21	Use the extra switch or the touch panel.
Low Battery The battery level is low. Charge the battery.	No.22	Charge the battery.

Display		Measures
Touch panel	Monitor	
Table Section Collision The leg plate is about to contact the frame.	No.23	To continue the current operation, perform the operations below. • Leg plate bending: Up (→ Page 44) • Slide: To leg (→ Page 47)
Table Up Rotary Encoder The lift rotary encoder is not functioning. Request repairs from Mizuho or your distributor.	No.24	Request repairs from your distributor or Mizuho.
Trend Rotary Encoder The trendelenburg rotary encoder is not functioning. Request repairs from Mizuho or your distributor.	No.25	Request repairs from your distributor or Mizuho.
Tilt Rotary Encoder The lateral tilt rotary encoder is not functioning. Request repairs from Mizuho or your distributor.	No.26	Request repairs from your distributor or Mizuho.
Back Rotary Encoder The back plate rotary encoder is not functioning. Request repairs from Mizuho or your distributor.	No.27	Request repairs from your distributor or Mizuho.
Slide Head Leg Rotary Encoder The head-to-leg slide rotary encoder is not functioning. Request repairs from Mizuho or your distributor.	No.28	Request repairs from your distributor or Mizuho.
Slide Right Left Rotary Encoder The right-to-left slide rotary encoder is not functioning. Request repairs from Mizuho or your distributor.	No.29	Request repairs from your distributor or Mizuho.
Leg Rotary Encoder The leg plate rotary encoder is not functioning. Request repairs from Mizuho or your distributor.	No.30	Request repairs from your distributor or Mizuho.
Hand Control Connection The control unit isn't connected.	No.31	Check if the control unit is connected.
Encoder PCB2 Communication The Rotary encoder PCB2 cannot be communicated with. Request repairs from Mizuho or your distributor.	No.32	Request repairs from your distributor or Mizuho.
Memory Function Because there is abnormality in the encoder function, the memory function can't be used.	No.33	Request repairs from your distributor or Mizuho.

● Error/warning for the touch panel

Monitor	Measures
Panel Err.	Request repairs from your distributor or Mizuho.

10. Before contacting for repairs

■ Checking causes and countermeasures

The following problems can occur even if the operating table is not malfunctioning. Check the following points before requesting repairs.

Status	Possible cause	Measures
The AC power cannot be turned on.	The power switch is OFF.	Check the power cord is connected and then turn on the power switch. (→ Page 25)
The battery cannot be turned on.	The battery is fully discharged. (No.9)	Charge the battery. (→ Page 27)
The battery cannot be charged.	The power switch is OFF.	Check the power cord is connected and then turn on the power switch. (→ Page 25)
A switch on the control unit does not function.	You did not press the E switch before the function switch.	Press E switch first and then the function switch. (→ Page 35 to 55)
	The pump motor thermal switch is activated. (No.16)	Wait for about 30 minutes to operate.
The operating table moves slowly.	The operation speed is set to the low speed mode.	Switch the high speed mode. (→ Page 35)
The operating table does not move.	The emergency stop switch has been pressed. (No.8)	Cancel the emergency stop switch. (→ Page 37)
A buzzer sounds when the power is turned on.	The emergency stop switch has been pressed. (No.8)	Cancel the emergency stop switch. (→ Page 37)
The operating table cannot be locked.	The emergency brake release dial is in the release (UNLOCK) position.	Turn the emergency brake release dial toward "LOCK". (→ Page 72)
The touch panel does not work.	The touch panel is pressed with two or more buttons together.	Tap the buttons one by one to operate the touch panel. (→ Page 14 to Page 18, Page 30 to Page 34)
The control unit cannot be operated wirelessly.	The rechargeable battery of the control unit is completely discharged.	Connect the control unit to the operating table and charge it. (→ Page 24)
The operating table stops at positions other than the level and center positions.	The memory mode is activated.	Press the "MEM" button on the control unit to activate the normal mode. (→ Page 51)

Status	Possible cause	Measures
The lift of the operating table cannot be executed in the down direction.	The head plate almost comes in contact with the floor, and a message appeared. (No.2)	Execute the following operations. <ul style="list-style-type: none"> • Reverse Trendelenburg (→ Page 40) • Back plate bending: Up (→ Page 42)
	The waist plate almost comes in contact with the base, and a message appeared. (No.3)	Execute the following operations in the return direction. <ul style="list-style-type: none"> • Lateral tilt (→ Page 39) • Trendelenburg (→ Page 40)
	The leg plate almost comes in contact with the lift linkage, and a message appeared. (No.4)	Bend the leg plate of the operating table upward. (→ Page 44)
	There is something below the lift linkage. (No.14)	Remove the object.
	The lift linkage almost comes in contact with the Trendelenburg frame, and a message appeared. (No.15)	Trendelenburg the operating table in the head down direction. (→ Page 40)
The Trendelenburg of the operating table cannot be executed in the head down direction.	The head plate almost comes in contact with the floor, and a message appeared. (No.2)	Execute the following operations. <ul style="list-style-type: none"> • Back plate bending: Up (→ Page 42) • Lift Up (→ Page 45)
	The waist plate almost comes in contact with the base, and a message appeared. (No.3)	Execute the following operations. <ul style="list-style-type: none"> • Lateral tilt in the return direction (→ Page 39) • Lift Up (→ Page 45)
The reverse Trendelenburg of the operating table cannot be executed in the head up direction.	The waist plate almost comes in contact with the base, and a message appeared. (No.3)	Execute the following operations. <ul style="list-style-type: none"> • Lateral tilt in the return direction (→ Page 39) • Lift Up (→ Page 45)
	The leg plate almost comes in contact with the lift linkage, and a message appeared. (No.4)	Bend the leg plate of the operating table upward. (→ Page 44)
	The lift linkage almost comes in contact with the Trendelenburg frame, and a message appeared. (No.15)	Lift the operating table. (→ Page 45)
The lateral tilt of the operating table cannot be executed in the right down direction.	The head plate almost comes in contact with the floor, and a message appeared. (No.2)	Execute the following operations. <ul style="list-style-type: none"> • Reverse Trendelenburg (→ Page 40) • Back plate bending: Up (→ Page 42) • Lift Up (→ Page 45)
	The waist plate almost comes in contact with the base, and a message appeared. (No.3)	Execute the following operations. <ul style="list-style-type: none"> • Trendelenburg in the return direction (→ Page 40) • Lift Up (→ Page 45)
	The leg plate almost comes in contact with the lift linkage, and a message appeared. (No.4)	Bend the leg plate of the operating table upward. (→ Page 44)
	The slide rail almost comes in contact with the lift cover, and a message appeared. (No.20)	Execute the Trendelenburg of the operating table to the level position or the reverse Trendelenburg position. (→ Page 40)

Status	Possible cause	Measures
The lateral tilt of the operating table cannot be executed in the left down direction.	The head plate almost comes in contact with the floor, and a message appeared. (No.2)	Execute the following operations. <ul style="list-style-type: none"> • Reverse Trendelenburg (→ Page 40) • Back plate bending: Up (→ Page 42) • Lift Up (→ Page 45)
	The waist plate almost comes in contact with the base, and a message appeared. (No.3)	Execute the following operations. <ul style="list-style-type: none"> • Trendelenburg in the return direction (→ Page 40) • Lift Up (→ Page 45)
	The leg plate almost comes in contact with the lift linkage, and a message appeared. (No.4)	Bend the leg plate of the operating table upward. (→ Page 44)
	The slide rail almost comes in contact with the lift cover, and a message appeared. (No.20)	Execute the Trendelenburg of the operating table to the level position or the reverse Trendelenburg position. (→ Page 40)
The back plate bending of the operating table cannot be executed in the down direction.	The head plate almost comes in contact with the floor, and a message appeared. (No.2)	Execute the following operations. <ul style="list-style-type: none"> • Reverse Trendelenburg (→ Page 40) • Lift Up (→ Page 45)
The slide of the operating table cannot be executed in the head direction.	The head plate almost comes in contact with the floor, and a message appeared. (No.2)	Execute the following operations. <ul style="list-style-type: none"> • Reverse Trendelenburg (→ Page 40) • Lift Up (→ Page 45)
	The waist plate almost comes in contact with the base, and a message appeared. (No.3)	Execute the following operations. <ul style="list-style-type: none"> • Lateral tilt in the return direction (→ Page 39) • Trendelenburg in the return direction (→ Page 40) • Lift Up (→ Page 45)
	The leg plate almost comes in contact with the frame, and a message appeared. (No.23)	Bend the leg plate of the operating table upward. (→ Page 44)
The slide of the operating table cannot be executed in the right direction.	The head plate almost comes in contact with the floor, and a message appeared. (No.2)	Execute the following operations. <ul style="list-style-type: none"> • Reverse Trendelenburg (→ Page 40) • Lift Up (→ Page 45)
	The waist plate almost comes in contact with the base, and a message appeared. (No.3)	Execute the following operations. <ul style="list-style-type: none"> • Lateral tilt in the return direction (→ Page 39) • Trendelenburg in the return direction (→ Page 40) • Lift Up (→ Page 45)
	The leg plate almost comes in contact with the lift linkage, and a message appeared. (No.4)	Bend the leg plate of the operating table upward. (→ Page 44)

Status	Possible cause	Measures
The slide of the operating table cannot be executed in the left direction.	The head plate almost comes in contact with the floor, and a message appeared. (No.2)	Execute the following operations. <ul style="list-style-type: none"> • Reverse Trendelenburg (→ Page 40) • Lift Up (→ Page 45)
	The waist plate almost comes in contact with the base, and a message appeared. (No.3)	Execute the following operations. <ul style="list-style-type: none"> • Lateral tilt in the return direction (→ Page 39) • Trendelenburg in the return direction (→ Page 40) • Lift Up (→ Page 45)
	The leg plate almost comes in contact with the lift linkage, and a message appeared. (No.4)	Bend the leg plate of the operating table upward. (→ Page 44)
The leg plate bending of the operating table cannot be executed in the down direction.	The leg plate almost comes in contact with the lift linkage, and a message appeared. (No.4)	Execute the following operations. <ul style="list-style-type: none"> • Trendelenburg (→ Page 40) • Lift Up (→ Page 45)
	The leg plate almost comes in contact with the frame, and a message appeared. (No.23)	Slide the the operating table in the leg direction. (→ Page 47)

If the situation does not improve even if the above countermeasures are implemented, request repairs from your distributor or Mizuho.

■ In case of malfunction

Implement the follow measures when the operating table is broken.

1. Turn the power switch off and disconnect the power cord from the medical grade outlet.
2. Place an "Out of Order" or "Do Not Use" sign on the operating table.



- The operating table should only be serviced or maintained by Mizuho or the certified providers. Make sure to contact your distributor or Mizuho for maintenance or repairs.
- Do not disassemble the operating table. Unauthorized disassembling may cause a fire, electrical shock or malfunction.
- In order to prevent infections, make sure to clean and disinfect the operating table when requesting to have it repaired.
- Do not put the product to be repaired in a MRI room.

■ Maintenance by providers

For safety use of this product, make sure to perform the periodical inspection by Mizuho or the certified provider once a year. Inspections and maintenances by other than Mizuho or the certified provider could cause any adverse event such as deterioration of the performance and functions.

For request for the periodical inspection, contact your distributor or Mizuho.

■ Warranty

MIZUHO Corporation will repair defective parts of this product without charge for one year from the date of delivery/installment except for cases of damage caused by a third party's repair, act of nature, improper use or damage on purpose. All other warranty terms and conditions are subject to regulations of MIZUHO Corporation.

App.-1 Electromagnetic compatibility

Medical Electrical Equipment needs special precautions regarding EMC and needs to be installed and put into service according to the EMC information provided in this manual.

Portable and mobile RF communications equipment can affect Medical Electrical Equipment.

The use of Accessories, transducers, and cables other than those specified, with the exception of transducers and cables sold by the Manufacturer of this device as replacement parts for internal components, may result in increased Emissions or decreased Immunity of Operating Table MST-7300BX-MRI.

Operating Table MST-7300BX-MRI should not be used adjacent to or stacked with other equipment and that if adjacent or stacked use is necessary, Operating Table MST-7300BX-MRI should be observed to verify normal operation in the configuration in which it will be used.

GUIDANCE AND MANUFACTURER'S DECLARATION – ELECTROMAGNETIC EMISSION		
Operating Table MST-7300BX-MRI is intended for use in the electromagnetic environment specified below. The customer or the user of Operating Table MST-7300BX-MRI should assure that it is used in such an environment.		
Emissions test	Compliance	Electromagnetic environment – guidance
RF emissions CISPR 11	Group 1	Operating Table MST-7300BX-MRI uses RF energy only for its internal function. Therefore, its RF emissions are very low and are not likely to cause any interference in nearby electronic equipment.
RF emissions CISPR 11	Class A	Operating Table MST-7300BX-MRI is suitable for use in all establishments, other than domestic establishments and those directly connected to the public low-voltage power supply network that supplies buildings used for domestic purposes.
Harmonic emissions IEC 61000-3-2	Class A	
Voltage fluctuations / flicker emissions IEC 61000-3-3	Complies	

RECOMMENDED SEPARATION DISTANCES BETWEEN PORTABLE AND MOBILE RF COMMUNICATIONS EQUIPMENT AND Operating Table MST-7300BX-MRI

Operating Table MST-7300BX-MRI is intended for use in an electromagnetic environment in which radiated RF disturbances are controlled. The customer or the user of Operating Table MST-7300BX-MRI can help prevent electromagnetic interference by maintaining a minimum distance between portable and mobile RF communications equipment (transmitters) and Operating Table MST-7300BX-MRI as recommended below, according to the maximum output power of the communications equipment.

Rated maximum output power of transmitter W	Separation distance according to frequency of transmitter m		
	150 kHz to 80 MHz	80 MHz to 800 MHz	800 MHz to 2,5 GHz
	$d = 1.2\sqrt{P}$	$d = 1.2\sqrt{P}$	$d = 2.3\sqrt{P}$
0,01	0.12	0.12	0.23
0,1	0.38	0.38	0.73
1	1.2	1.2	2.3
10	3.8	3.8	7.3
100	12	12	23

For transmitters rated at a maximum output power not listed above, the recommended separation distance **d** in metres (m) can be estimated using the equation applicable to the frequency of the transmitter, where **P** is the maximum output power rating of the transmitter in watts (W) according to the transmitter manufacturer.

NOTE 1: At 80 MHz and 800 MHz, the separation distance for the higher frequency range applies.

NOTE 2: These guidelines may not apply in all situations. Electromagnetic propagation is affected by absorption and reflection from structures, objects and people.

GUIDANCE AND MANUFACTURER'S DECLARATION – ELECTROMAGNETIC IMMUNITY

Operating Table MST-7300BX-MRI is intended for use in the electromagnetic environment specified below. The customer or the user of Operating Table MST-7300BX-MRI should assure that it is used in such an environment.

Immunity test	IEC 60601 test level	Compliance level	Electromagnetic environment – guidance
Electrostatic discharge (ESD) IEC 61000-4-2	±6 kV contact ±8 kV air	±6 kV contact ±8 kV air	Floors should be wood, concrete or ceramic tile. If floors are covered with synthetic material, the relative humidity should be at least 30%
Electrical fast transient/burst IEC 61000-4-4	±2 kV for power supply lines ±1 kV for input/output lines	±2 kV for power supply lines ±1 kV for input/output lines	Mains power quality should be that of a typical commercial or hospital environment.
Surge IEC 61000-4-5	±1 kV line(s) to line(s) ±2 kV line(s) to earth	±1 kV line(s) to line(s) ±2 kV line(s) to earth	Mains power quality should be that of a typical commercial or hospital environment.
Voltage dips, short interruptions and voltage variations on power supply input lines IEC 61000-4-11	<5 % U_T (>95 % dip in U_T) for 0.5 cycle 40 % U_T (60 % dip in U_T) for 5 cycles 70 % U_T (30 % dip in U_T) for 25 cycles <5 % U_T (>95 % dip in U_T) for 5 sec	<5 % U_T (>95 % dip in U_T) for 0.5 cycle 40 % U_T (60 % dip in U_T) for 5 cycles 70 % U_T (30 % dip in U_T) for 25 cycles <5 % U_T (>95 % dip in U_T) for 5 sec	Mains power quality should be that of a typical commercial or hospital environment. If the user of Operating Table MST-7300BX-MRI requires continued operation during power mains interruptions, it is recommended that Operating Table MST-7300BX-MRI be powered from an uninterruptible power supply or a battery.
Power frequency (50/60 Hz) magnetic field IEC 61000-4-8	3 A / m	3 A / m	Power frequency magnetic fields should be at levels characteristic of a typical location in a typical commercial or hospital environment

NOTE: U_T is the a.c. mains voltage prior to application of the test level.

GUIDANCE AND MANUFACTURER'S DECLARATION – ELECTROMAGNETIC IMMUNITY

Operating Table MST-7300BX-MRI is intended for use in the electromagnetic environment specified below. The customer or the user of Operating Table MST-7300BX-MRI should assure that it is used in such an environment.

Immunity test	IEC 60601 test level	Compliance level	Electromagnetic environment – guidance
Conducted RF IEC 61000-4-6	3 Vrms 150 kHz to 80 MHz	3 Vrms 150 kHz to 80 MHz	<p>Portable and mobile RF communications equipment should be used no closer to any part of Operating Table MST-7300BX-MRI, including cables, than the recommended separation distance calculated from the equation applicable to the frequency of the transmitter.</p> <p>Recommended separation distance</p> $d = 1.2\sqrt{P}$ $d = 1.2\sqrt{P} \text{ 80 MHz to 800 MHz}$ $d = 2.3\sqrt{P} \text{ 800 MHz to 2.5 GHz}$ <p>where P is the maximum output power rating of the transmitter in watts (W) according to the transmitter manufacturer and d is the recommended separation distance in metres (m).</p> <p>Field strengths from fixed RF transmitters, as determined by an electromagnetic site survey, ^a should be less than the compliance level in each frequency range. ^b Interference may occur in the vicinity of equipment marked with the following symbol:</p> 
Radiated RF IEC 61000-4-3	3 V/m 80 MHz to 2.5 GHz	3 V/m 80 MHz to 2.5 GHz	

NOTE 1: At 80 MHz and 800 MHz, the higher frequency range applies.

NOTE 2: These guidelines may not apply in all situations. Electromagnetic propagation is affected by absorption and reflection from structures, objects and people.

^a Field strengths from fixed transmitters, such as base stations for radio (cellular/cordless) telephones and land mobile radios, amateur radio, AM and FM radio broadcast and TV broadcast cannot be predicted theoretically with accuracy. To assess the electromagnetic environment due to fixed RF transmitters, an electromagnetic site survey should be considered. If the measured field strength in the location in which Operating Table MST-7300BX-MRI is used exceeds the applicable RF compliance level above, Operating Table MST-7300BX-MRI should be observed to verify normal operation. If abnormal performance is observed, additional measures may be necessary, such as re-orienting or relocating Operating Table MST-7300BX-MRI.

^b Over the frequency range 150 kHz to 80 MHz, field strengths should be less than 3 V/m.

App.-2 Glossary

Base

The light-blue portion of the figure below.

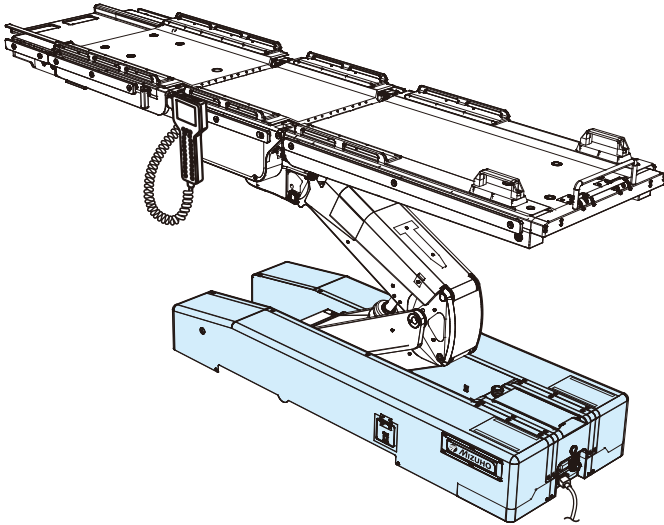

Back plate lock

To turn the transfer board releasing levers (for the back plate), which are attached to both sides of the back plate, to LOCK to lock the transfer board. The lock is released by putting the lever to FREE.

Lateral tilt

Tabletop of the operating table moves to the left-down or the right-down position in the view from the head side.

Tabletop

The light-blue portion of the figure below.

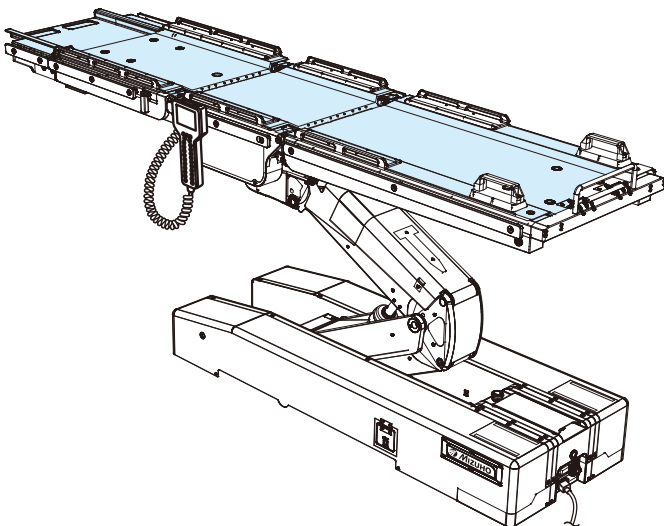

Leg plate lock

To put the transfer board entirely on the table top to lock them automatically. The lock is released by lowering the transfer board releasing lever (for the leg plate), which is attached to the tip of the leg plate.

Trendelenburg

Tabletop of the operating table moves to the head-up or the head-down position.



Authorized Representative Europe:



Emergo Europe B.V.
Prinsessegracht 20, 2514 AP
The Hague, The Netherlands

Sales Agent

Manufacturer:



MIZUHO Corporation

3-30-13 Hongo, Bunkyo-ku
Tokyo 113-0033, Japan
<http://www.mizuho.co.jp>